



Booth Building & Display Regulations

Carefully review this section for specific Toy Fair 2025 booth display regulations for tabletops and standard linear, perimeter, oversized, walk-thru, peninsula, and island booths. If you are not certain which type of booth you have selected or have other questions, please contact your Account Executive or Show Management. If a booth does not adhere to these regulations, exhibitors will be required to modify their exhibits on-site at their own expense.

Display Variances

If your booth display does not meet the guidelines specified, you have the option of requesting a variance from Show Management in writing by submitting the *Display Variance Request Form* ([download here](#)) and a diagram of your exhibit no later than Friday, December 6, 2024. Please understand that submitting a request for a variance does not guarantee approval.

Building and Safety Regulations of the Jacob K. Javits Convention Center

Jacob K. Javits Convention Center regulations governing the installation of exhibit structures may, in some cases, require exhibitors to acquire an approved Building Notice if it is possible to walk up, onto or beneath any form of ceiling or roof, or a second-tier booth.

If any of these structural designs exist in your booth, you are required to submit plans of the proposed structure to North American International Toy Fair Show Management. If, in the opinion of the Office of Fire and Safety at the Javits Center, a Building Notice is required, the following procedures apply.

1. The Exhibitor must retain, at its expense, an architect or engineer, licensed in New York State, to prepare drawings and applications for review by the Buildings Department of the City of New York.
2. The architect or engineer must submit drawings and applications for a Building Notice and meet with a Plans Examiner at the Buildings Department in Manhattan.
3. The Plans Examiner reviews the plans and, if approved, authorizes the right for a Building Permit to be issued to erect the structure. At this time, the department's inspectors may be notified of the approved plans.
4. The Exhibitor's contractor presents to the Buildings Department their Certificate of Insurance and obtains a Building Permit to construct the structure.
5. The contractor is required to display the permit for public viewing in a prominent location and the plans must be available for inspection.
6. Union labor will be required for the exhibit installation and dismantle. It is essential to review the *New York City, NY Labor Guidelines* located in the *T3 Expo Services* section of this *Exhibitor Kit* as well as the *Exhibitor Appointed Contractor Guidelines & Notification Form* under the *Exhibit Planning* section.

Please review the following Toy Fair 2025 regulations carefully. If you are not certain which type of booth you have selected, please contact your Account Executive or Show Management. If a booth does not adhere to these regulations, exhibitors will be required to modify their exhibits on-site at their own expense.

1. Standard Linear/Inline Booths

Definition: One or more standard units in a straight line.

Height Regulation: The maximum height for merchandise and/or display fixtures placed in the back 50% of the booth is 8ft. 3in. (2.5m). Merchandise and/or display fixtures placed in the front 50% of the booth may not exceed 4ft. (1.22m) in height within 10ft. (3.05m) of an adjoining booth.

Purpose: If a portion of an exhibit extends above 8ft. 3in. (2.5m) in height, the exhibit booth background will detract from the overall impact of the exhibit directly behind that booth regardless of how the rear of the offending exhibit is finished. Additionally, each exhibitor is entitled to a reasonable sightline from the aisle regardless of the size of the booth. Exhibitors with larger spaces (30 linear feet/9.14m) or more should also be able to effectively use as much of the total floor space as possible as long as they do not interfere with the rights of others. The limitation on display fixtures over 4ft. (1.22m) and within 10 linear ft. (3.05m) of a neighboring exhibit is intended to accomplish both of these goals.

For inline booths situated behind a peninsula or walk-thru booth, the maximum height on the shared side is 8 ft. (2.5m). Subject to variance approval by Show Management ([click here to download the Display Variance Request Form](#))

Notes: Back drape is 8' high and side drape is 3' high.

Any unfinished sides of displays must be covered or draped at the exhibitor's expense.

No product may be hung on the exterior side of display.

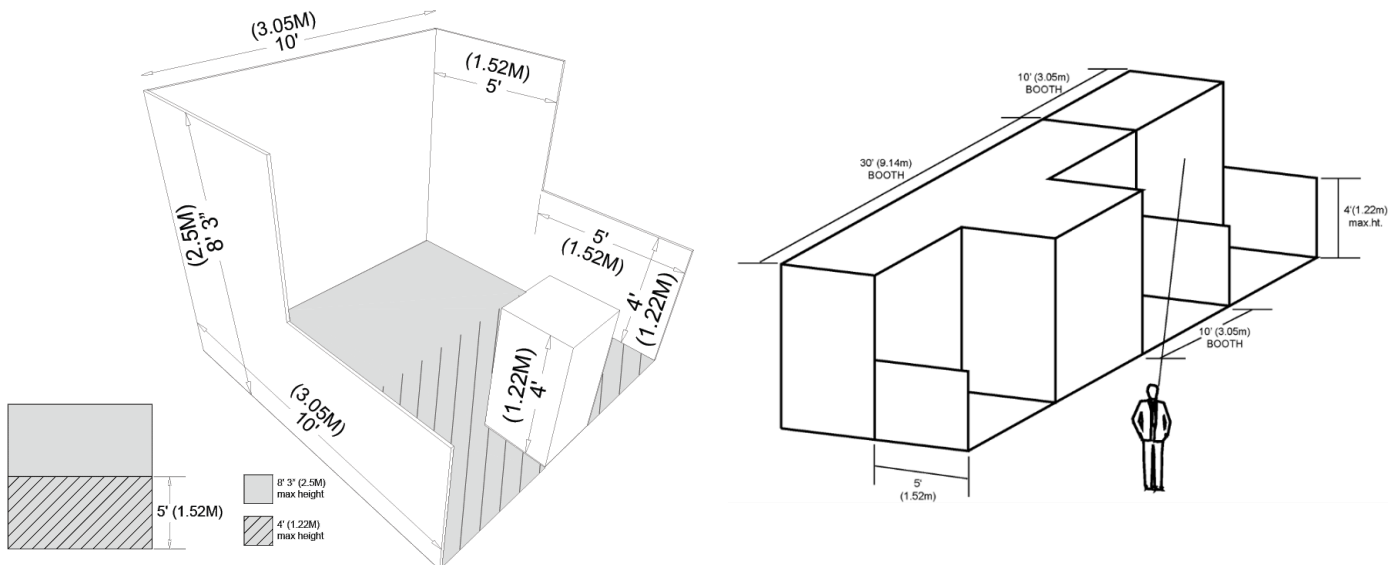

***Nothing may be taped, tacked, nailed, or screwed or affixed in any way to columns, walls, floors, or other Javits Center surfaces. Any damage caused by infraction of this rule will be repaired at the exhibitor's expense.**

2. Perimeter Wall Linear/Inline Booths

Definition: One or more standard units located on the perimeter wall of the exhibit floor.

Due to the lower ceiling height in Hall 3D (aisles 900, 1000, 1100 and 1200), perimeter wall linear/inline booths located under the low ceiling must adhere to the booth display regulations that apply to standard linear/inline booths.

Height Regulation for all other areas: The maximum height for merchandise and/or display fixtures placed in the back 50% of the booth is 12ft. (3.66m). Merchandise and/or display fixtures placed in the front 50% of the booth may not exceed 4ft. (1.22m) in height within 10ft. (3.05m) of an adjoining booth.

Purpose: Because the perimeter booths are not backed up against another exhibitor’s booth display, back walls and materials over 8ft. 3in. (2.5m) in height will not interfere with or detract from any other exhibit booth. Additionally, each exhibitor is entitled to a reasonable sightline from the aisle regardless of the size of the booth. Exhibitors with larger spaces (30 linear feet/9.14m) or more should also be able to effectively use as much of the total floor space as possible as long as they do not interfere with the rights of others. The limitation on display fixtures over 4ft. (1.22m) and within 10 linear ft. (3.05m) of a neighboring exhibit is intended to accomplish both of these goals.

Notes: Back drape is 8’ high and side drape is 3’ high (except front-of-hall spaces).

Any unfinished sides of displays must be covered or draped at the exhibitor’s expense.

No product may be hung on the exterior side of display.

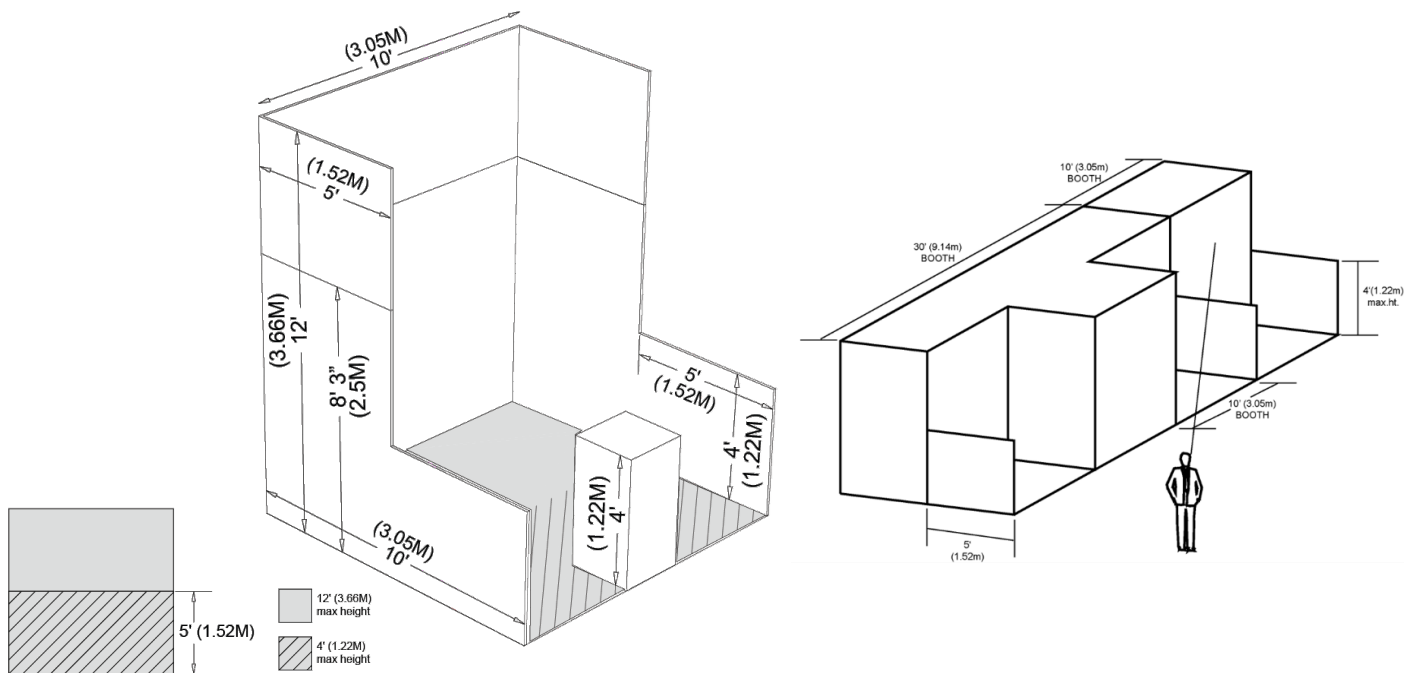

***Nothing may be taped, tacked, nailed, or screwed or affixed in any way to columns, walls, floors, or other Javits Center surfaces. Any damage caused by infraction of this rule will be repaired at the exhibitor’s expense.**

Booth Display Regulations

3. Oversized Linear/Inline Booths

Definition: An exhibit made up of four or more standard units back-to-back (i.e., 20'x20') with sidewalls adjacent to at least one neighboring exhibit.

All oversized linear/inline booth floor plan designs must be reviewed and approved by Show Management. Submissions must be received no later than Friday, November 1, 2024, [via link](#).

If a display does not adhere to these regulations, exhibitors will be required to modify their exhibits on-site at their own expense.

Visual Merchandising Initiative: All oversized linear/inline booths must contain visual merchandising of product(s) or properties on at least 20% of the aisle-facing exhibit square footage.

This regulation provides the flexibility to include showcases, plexiglass, low walls, open space, etc. See the following pages for booth examples.

Purpose: Each exhibit space has specific business purposes. To provide engagement requested by the buying community and to leverage media attention, the minimum 20% visual merchandising allows exhibitors to present in-year product readily visible while also having the flexibility to host private meetings for preview activity.

Height Regulation for Level 3: The maximum height for merchandise and display fixtures is 16ft. (4.88m). Any portion of the exhibit bordering another exhibitor's booth must have the back side of that portion finished and must not carry identification signs.

Height Regulation for Level 1: The maximum height for merchandise and display fixtures is 12ft. (3.66m). Any portion of the exhibit bordering another exhibitor's booth must have the back side of that portion finished and must not carry identification signs.

Notes: Back and side drapes are 8' high.

Any unfinished sides of displays must be covered or draped at the exhibitor's expense.

No product may be hung on the exterior side of display.

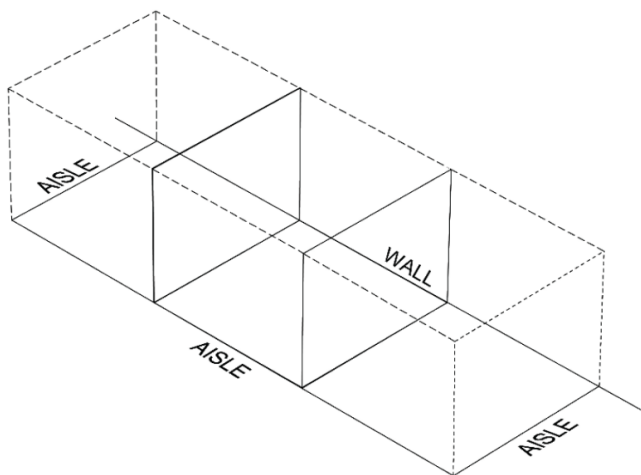

Level 3 - 16ft. (4.88m) max.
Level 1 - 12ft. (3.66m) max.

Structural Integrity

All multi-story exhibits, regardless of whether people will occupy the upper area or not, and all exhibit fixtures and components exceeding 12ft. (3.66m) in height must have drawings available for inspection by Show Management, the installation and dismantling contractor, the exhibitor and governmental authority. These must be available during the time the exhibit is being erected, exhibited and dismantled at the show site and must include a signature or stamp of a reviewing structural engineer indicating that the structure design is properly engineered for its proposed use, and a signature of an authorized official of the exhibit building company indicating that the structure is built in compliance with the details and specifications set forth on the drawings. Signs must also be posted indicating the maximum number of people the structure will accommodate.

*Nothing may be taped, tacked, nailed, or screwed or affixed in any way to columns, walls, floors, or other Javits Center surfaces. Any damage caused by infraction of this rule will be repaired at the exhibitor's expense.

Oversized Linear/Inline Booths

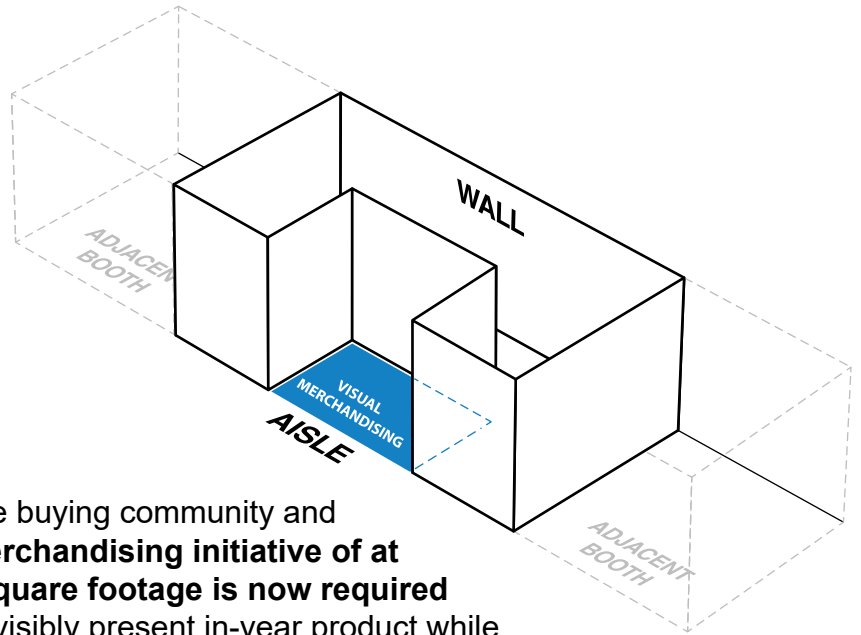

To provide engagement requested by the buying community and to leverage media attention, **a visual merchandising initiative of at least 20% of the aisle-facing exhibit square footage is now required for all exhibitors.** This will allow you to visibly present in-year product while also having the flexibility to host private meetings for preview activity.

To calculate the required visual merchandising space, (Length x Width) x 20%.

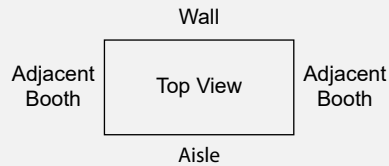

“Visual merchandising provides the flexibility to include window displays, windows, display cases, kneewalls, open space, etc.

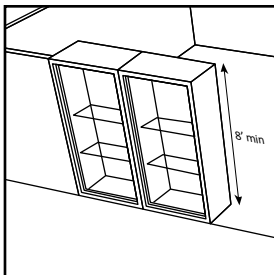

window display

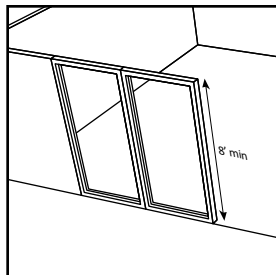

window

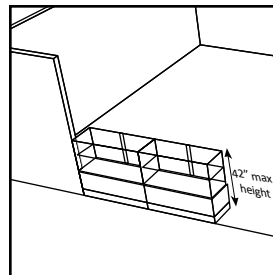

counter height display case

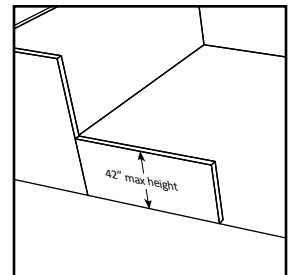

kneewall

Booth Layout Examples Top View

Key

- Booth Wall
- ▨ Visual Merchandising Space



Example A



Example B

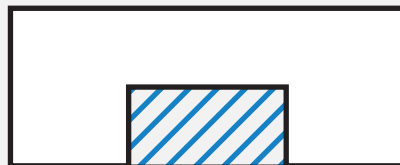

Example C

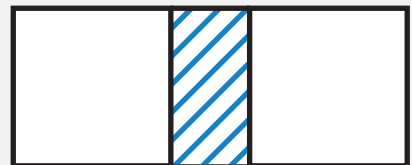

Example D

Oversized Linear/ Inline Booths

Example A

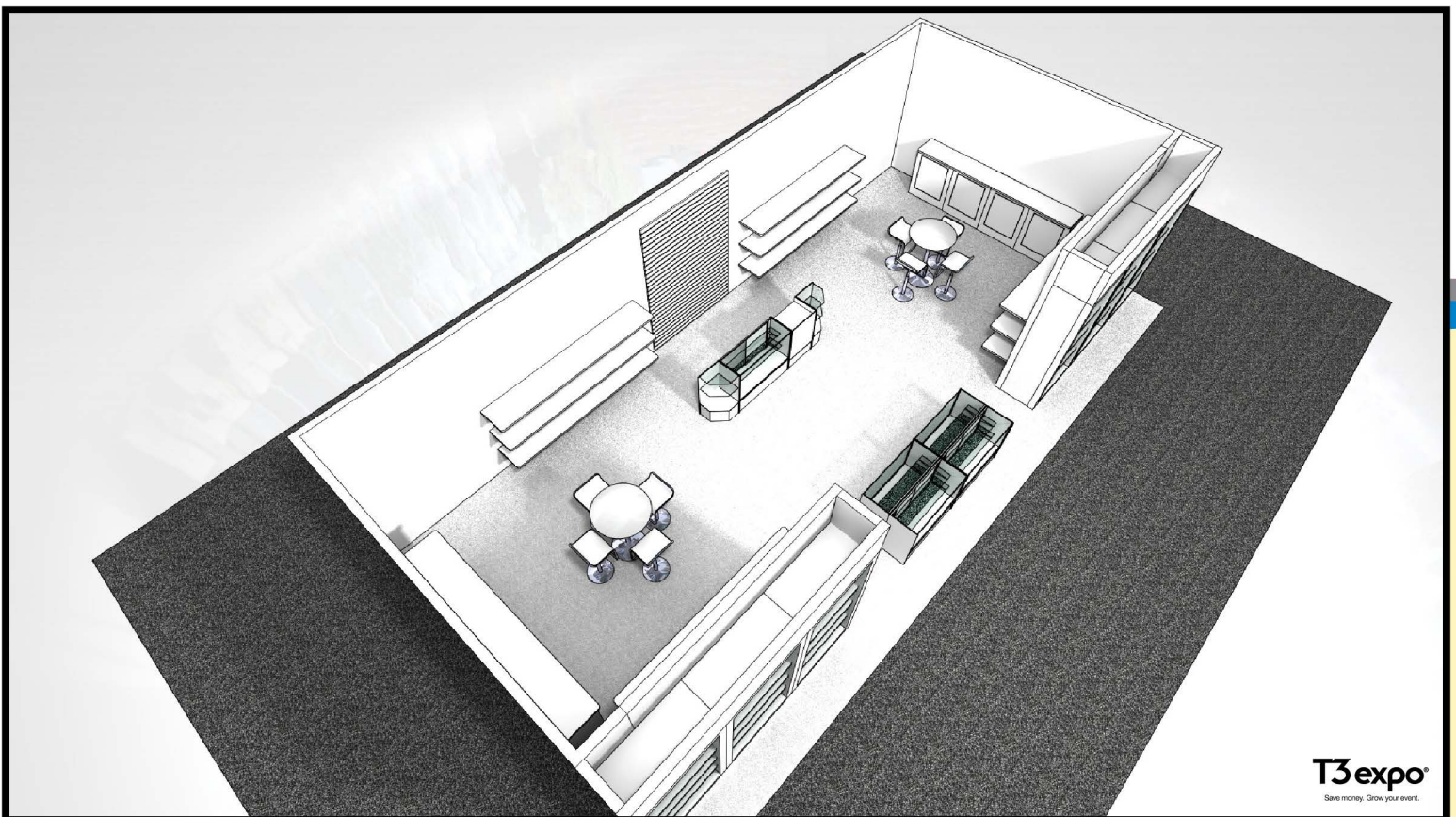
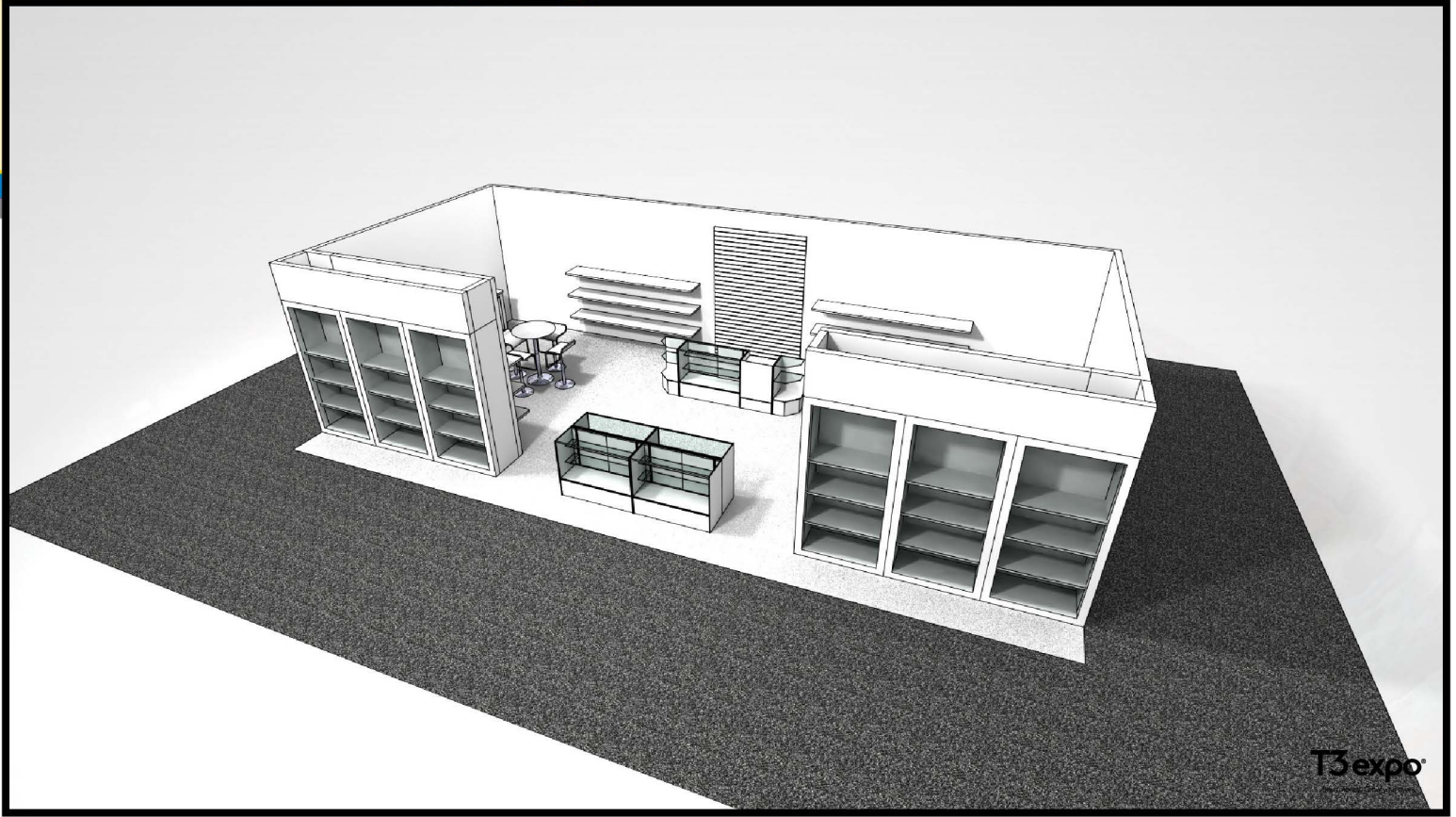

Oversized Linear/ Inline Booths

Example B

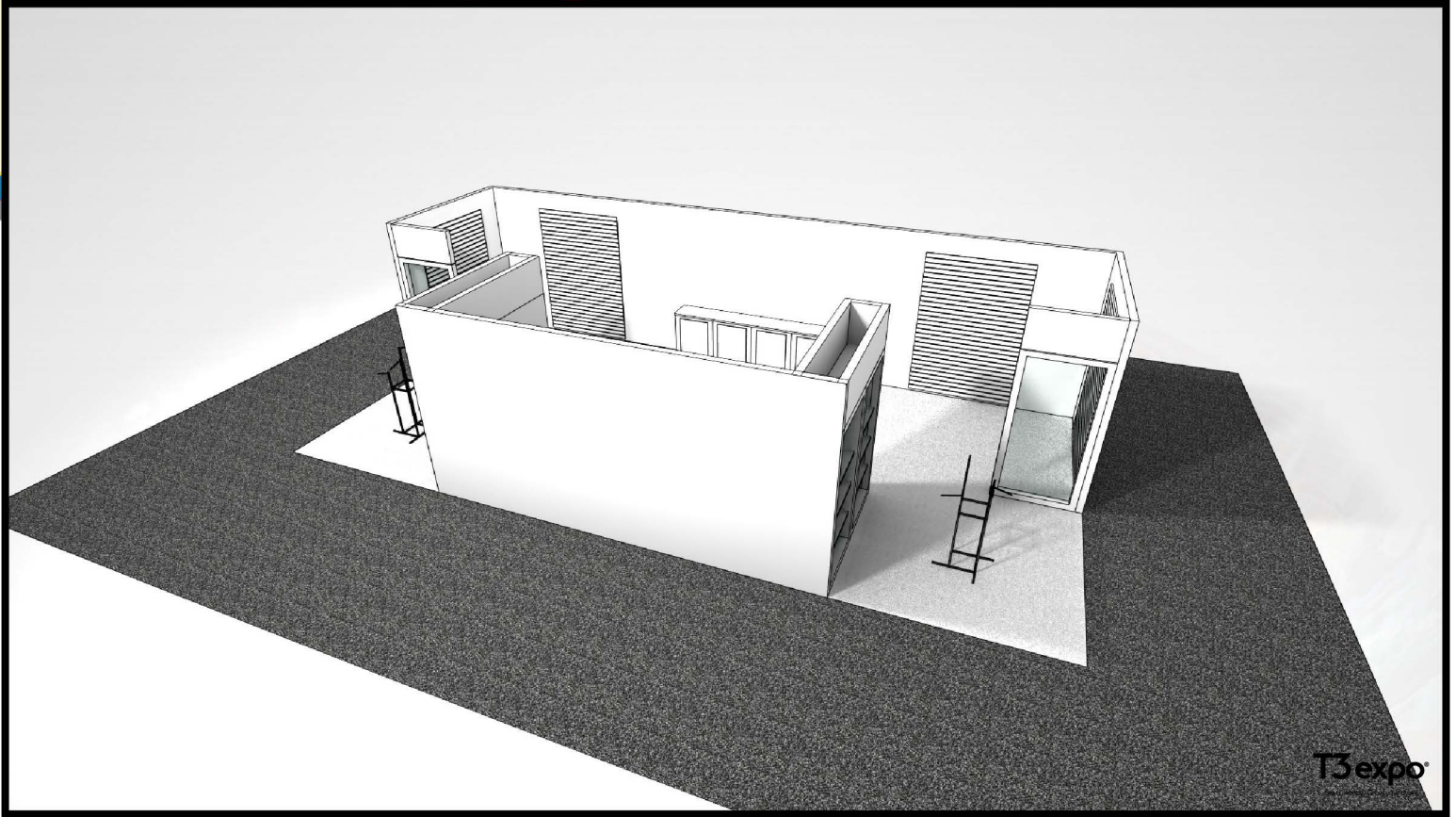

T3expo

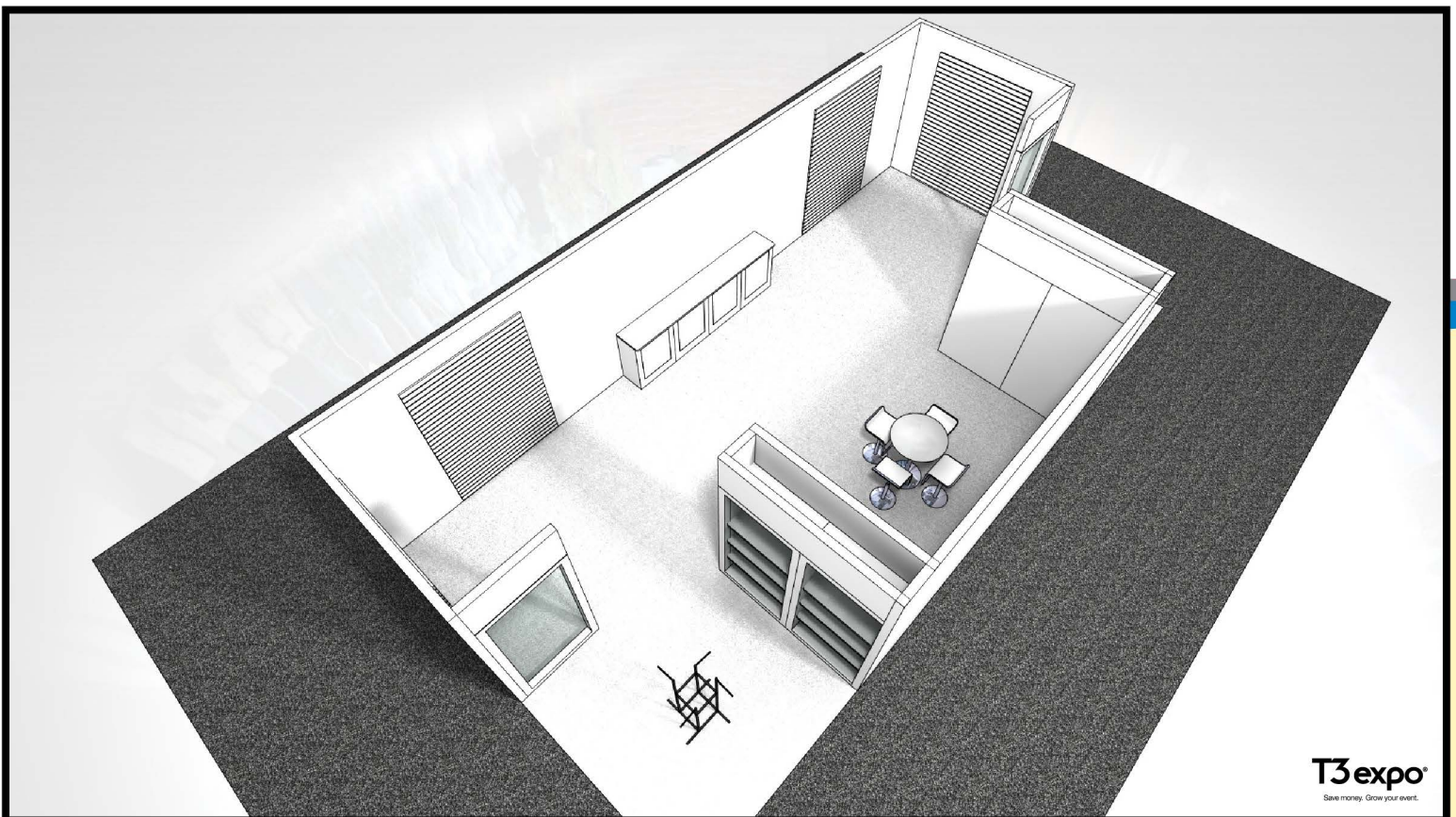

T3expo
Save money. Grow your event.

Oversized Linear/ Inline Booths

Example C

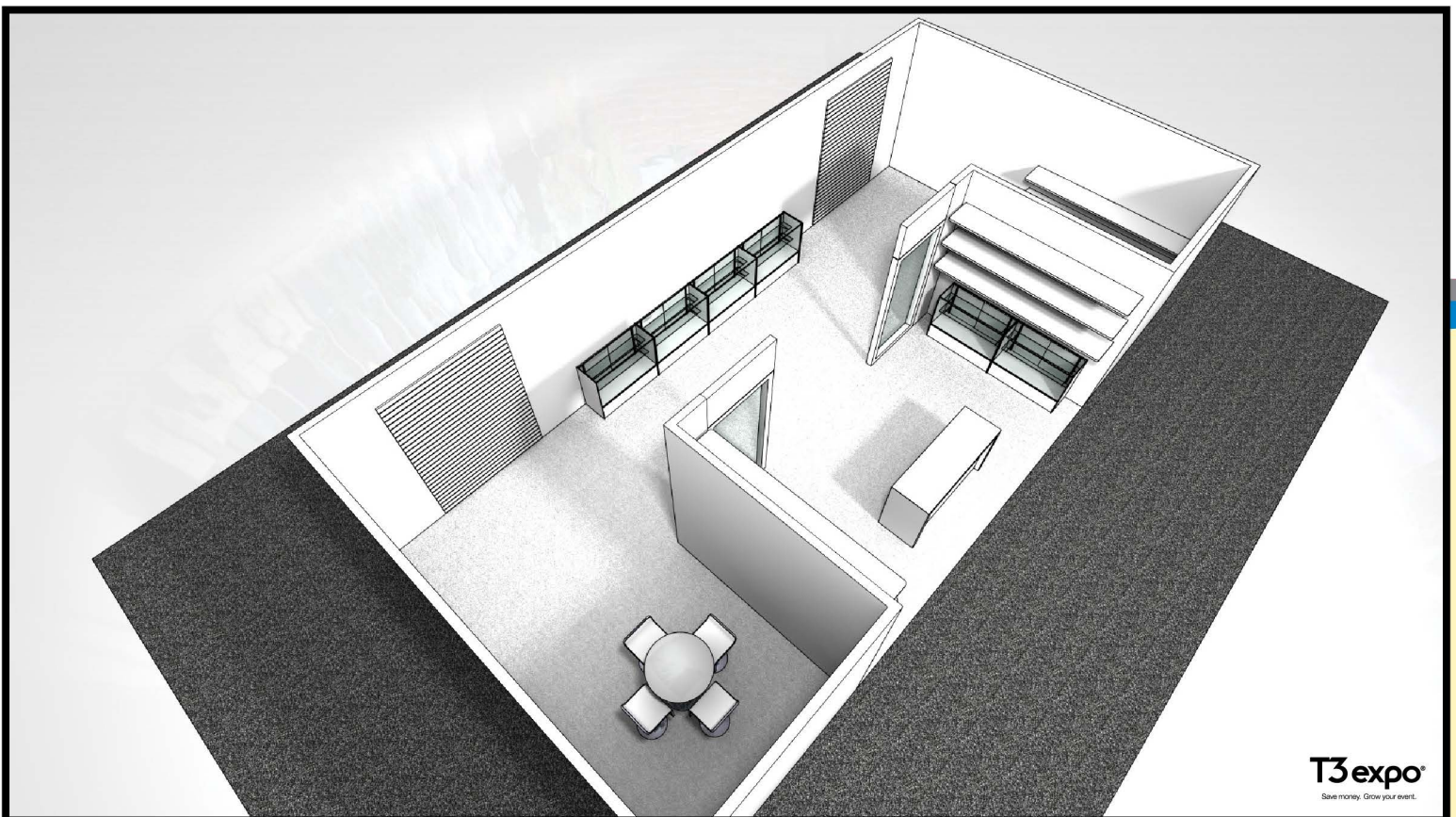
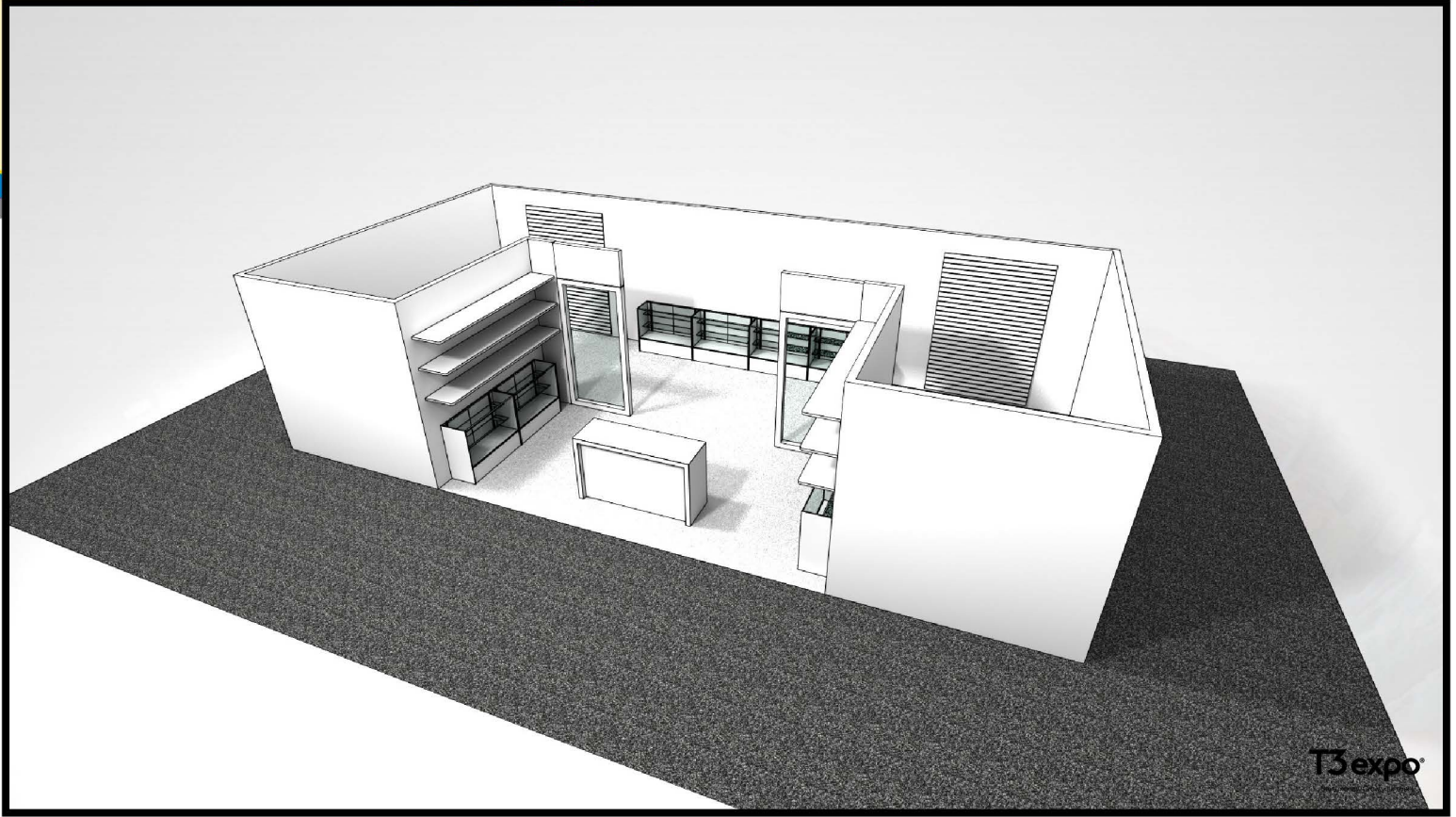
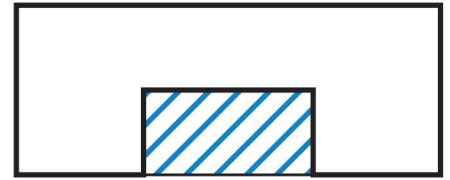

Oversized Linear/ Inline Booths

Example D

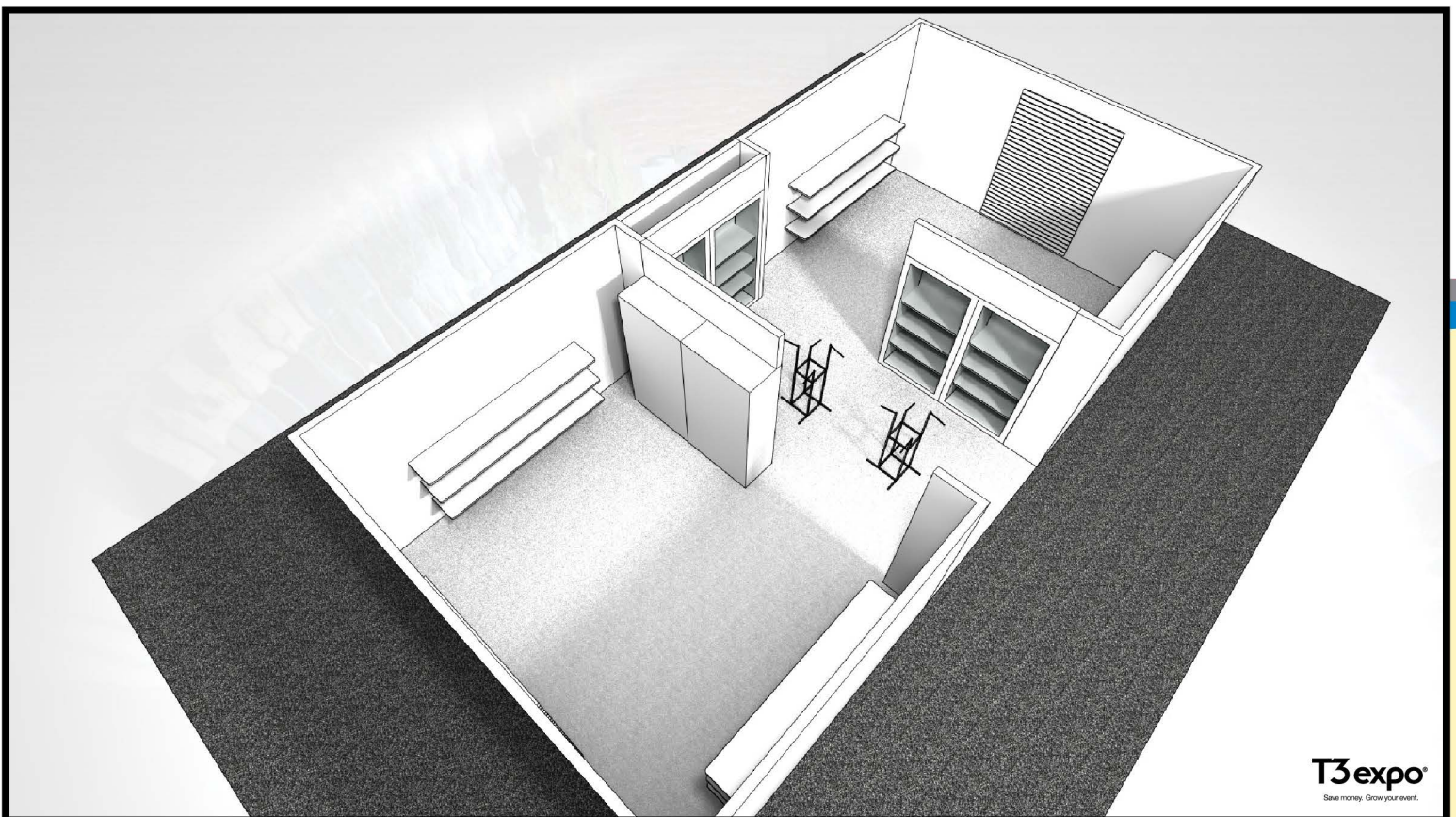
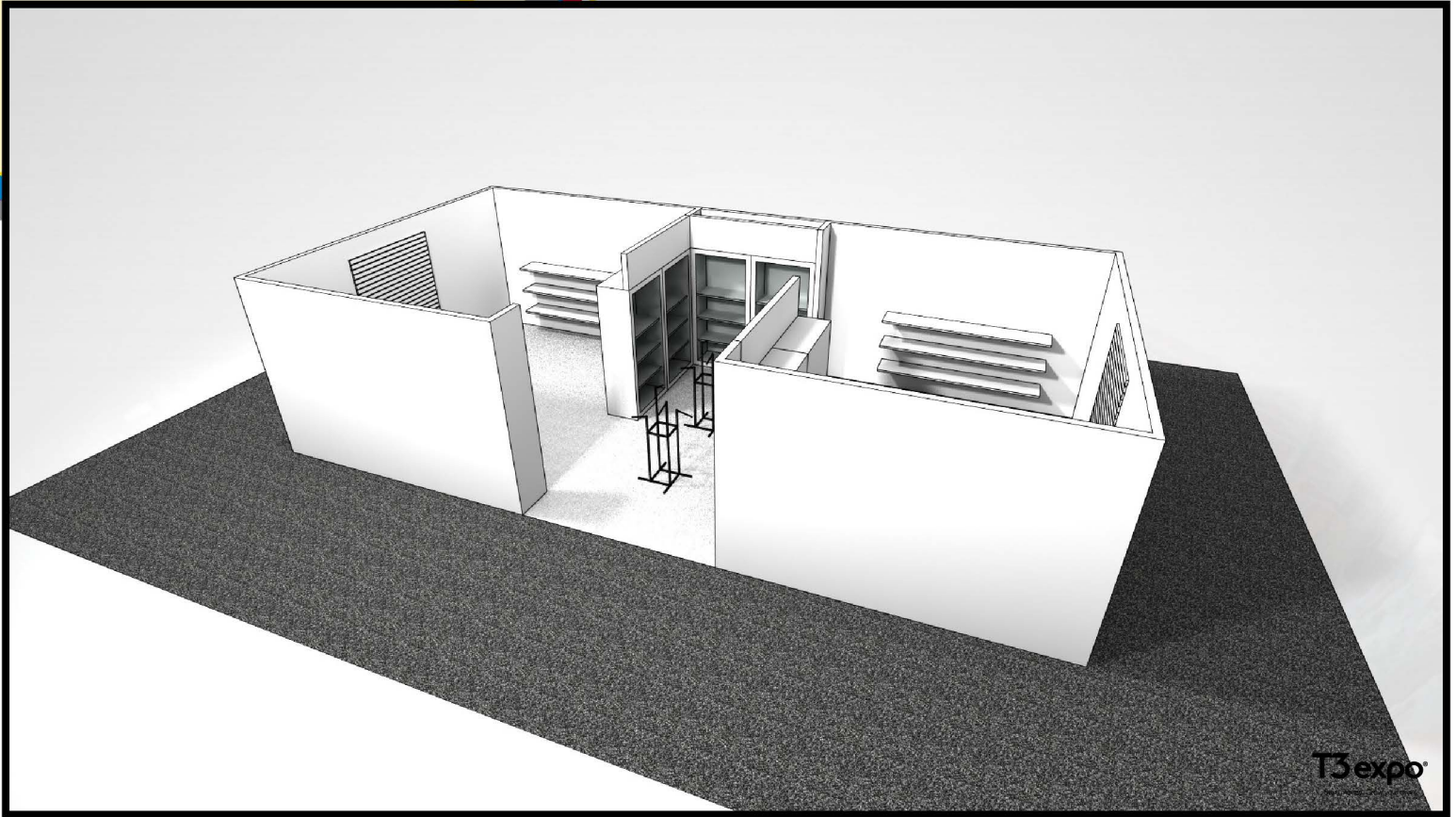
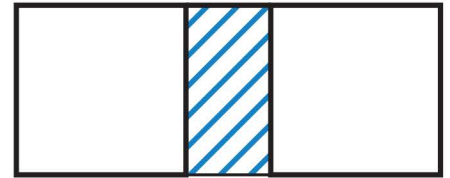

Booth Display Regulations

4. Walk-Thru Booths

Definition: An exhibit made up of four or more standard units back-to-back (i.e., 20'x20') with aisles on two parallel sides and situated between two or more booths.

All walk-thru booth floor plan designs must be reviewed and approved by Show Management. Submissions must be received no later than Friday, November 1, 2024, [via this link](#).

If a display does not adhere to these regulations, exhibitors will be required to modify their exhibits on-site at their own expense.

Visual Merchandising Initiative: All walk-thru booths must contain visual merchandising of product(s) or properties on at least 20% of the aisle-facing exhibit square footage.

This regulation provides the flexibility to include showcases, plexiglass, low walls, open space, etc. See the following pages for booth examples.

Purpose: Each exhibit space has specific business purposes. To provide engagement requested by the buying community and to leverage media attention, the minimum 20% visual merchandising allows exhibitors to present in-year product readily visible while also having the flexibility to host private meetings for preview activity.

Height Regulation for Level 3, Hall 3D (Aisles 900, 1000, 1100 & 1200): The maximum height for merchandise and display fixtures is 12ft. (3.66m). Any portion of the exhibit bordering another exhibitor's booth must have the back side of that portion finished and must not carry identification signs.

Height Regulation for all other areas on Level 3 (Halls 3, 3A, 3B & 3E): The maximum height for merchandise and display fixtures is 16ft. (4.88m). Any portion of the exhibit bordering another exhibitor's booth must have the back side of that portion finished and must not carry identification signs.

Height Regulation for Level 1: The maximum height for merchandise and display fixtures is 12ft. (3.66m). Any portion of the exhibit bordering another exhibitor's booth must have the back side of that portion finished and must not carry identification signs.

Notes: Side drapes are 8' high.

Any unfinished sides of displays must be covered or draped at the exhibitor's expense.

No product may be hung on the exterior side of display.

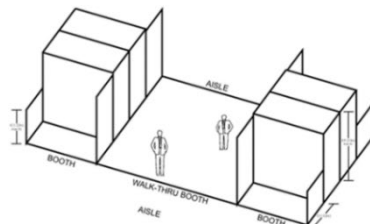

DISPLAY FIXTURES OVER 412.2cm
MUST BE FINISHED TO
THE AREA OF THE BOOTH THAT
IS AT LEAST 1.5m
FROM THE AISLE LINE

Level 3, Hall 3D - 12ft. (3.66m) max.
Level 3, Halls 3/3A/3B/3E - 16ft. (4.88m) max.
Level 1, Halls 1A/1B/1C - 12ft. (3.66m) max.

IMPORTANT:

Walk-Thru booths are normally between 2 or more booths. Any portion of the exhibitor's booth adjacent to another booth must have the back side of that portion finished and must not carry identification or other copy that would detract from the adjoining exhibit.

Structural Integrity

All multi-story exhibits, regardless of whether people will occupy the upper area or not, and all exhibit fixtures and components exceeding 12ft.(3.66m) in height must have drawings available for inspection by Show Management, the installation and dismantling contractor, the exhibitor and governmental authority. These must be available during the time the exhibit is being erected, exhibited and dismantled at the show site and must include a signature or stamp of a reviewing structural engineer indicating that the structure design is properly engineered for its proposed use, and a signature of an authorized official of the exhibit building company indicating that the structure is built in compliance with the details and specifications set forth on the drawings. Signs must also be posted indicating the maximum number of people the structure will accommodate.

*Nothing may be taped, tacked, nailed, or screwed or affixed in any way to columns, walls, floors, or other Javits Center surfaces. Any damage caused by infraction of this rule will be repaired at the exhibitor's expense.

Walk-Thru Booths

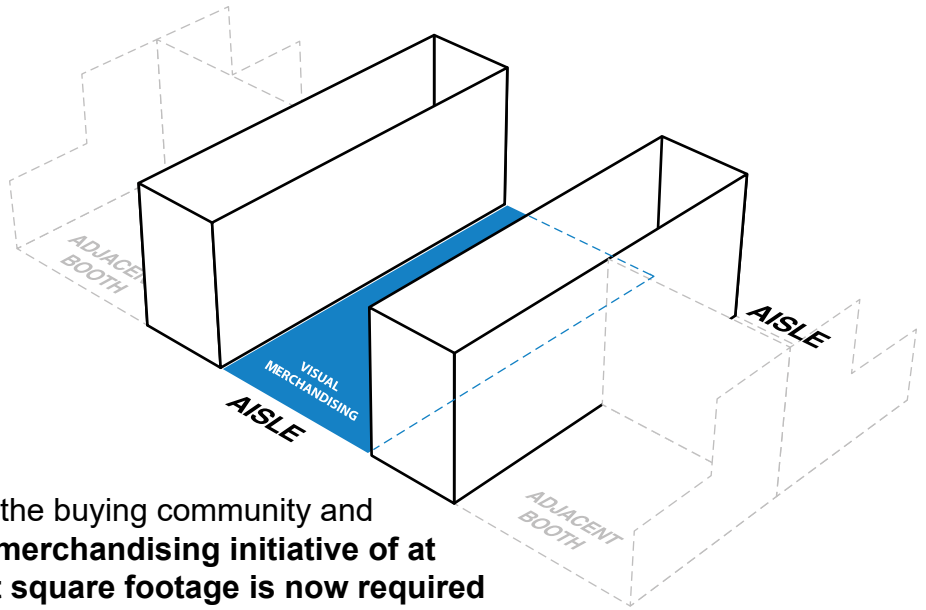

To provide engagement requested by the buying community and to leverage media attention, **a visual merchandising initiative of at least 20% of the aisle-facing exhibit square footage is now required for all exhibitors.** This will allow you to visibly present in-year product while also having the flexibility to host private meetings for preview activity.

To calculate the required visual merchandising space, $(\text{Length} \times \text{Width}) \times 20\%$.

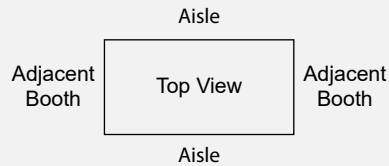

“Visual merchandising provides the flexibility to include window displays, windows, display cases, kneewalls, open space, etc.

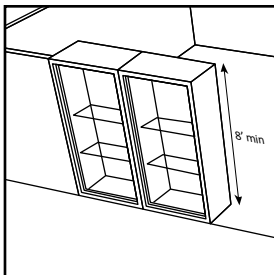

window display

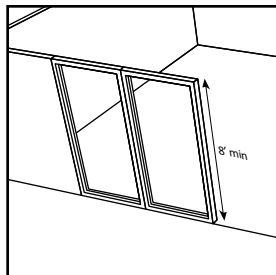

window

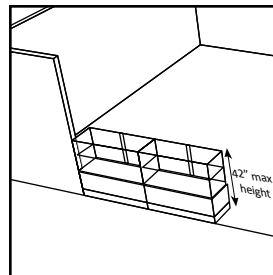

counter height display case

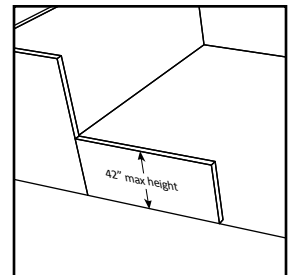

kneewall

Booth Layout Examples Top View

Key

- Booth Wall
- Visual Merchandising Space



Example A



Example B

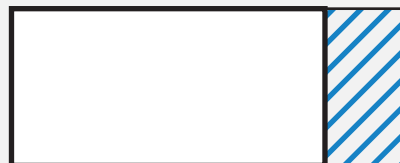

Example C

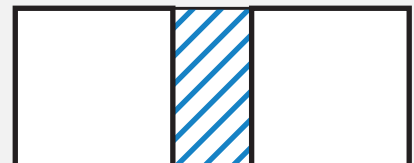

Example D

Walk-Thru Booths

Example A

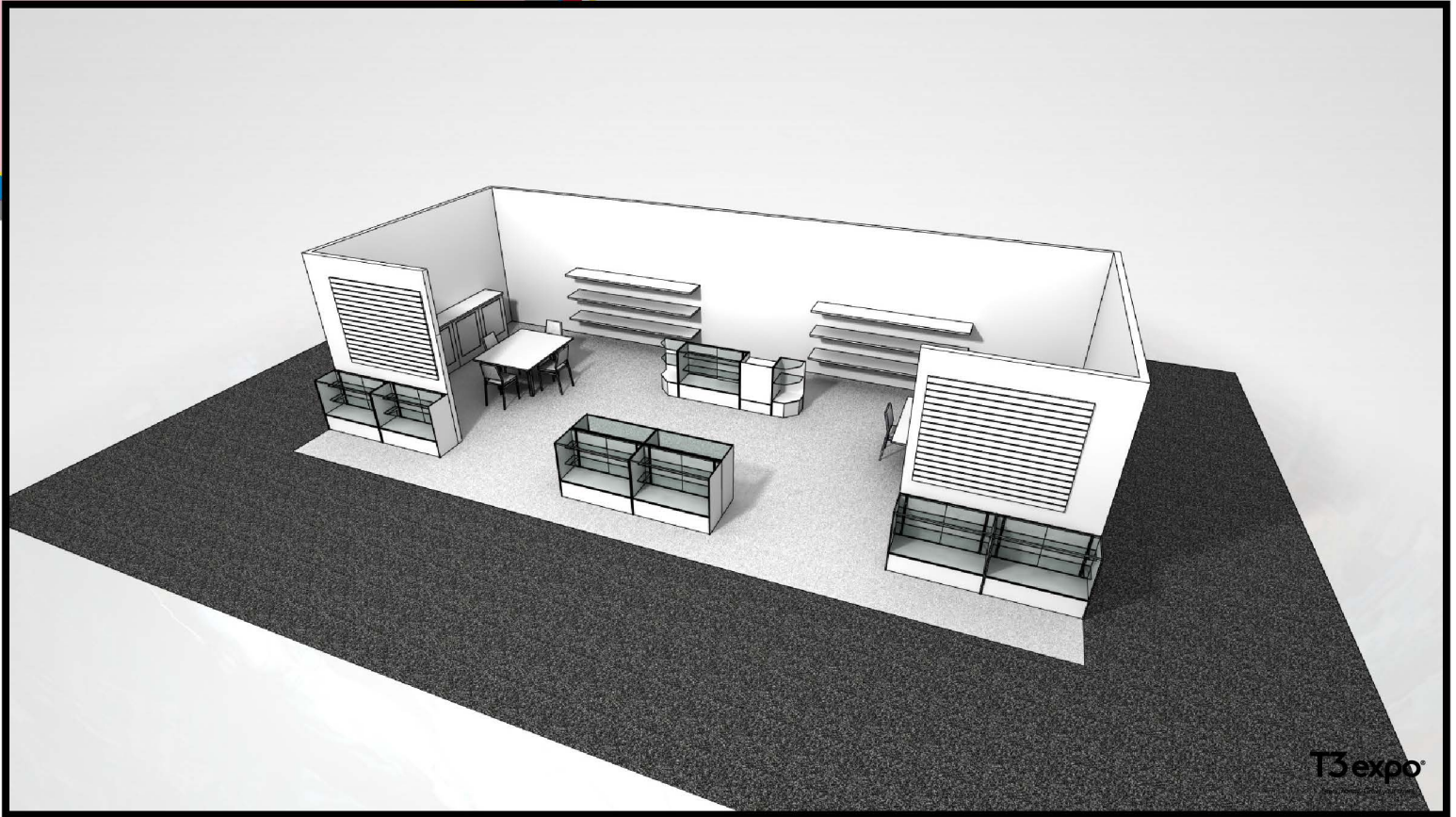

Walk-Thru Booths

Example B



T3expo



T3expo
Save money. Grow your event.

Walk-Thru Booths

Example C

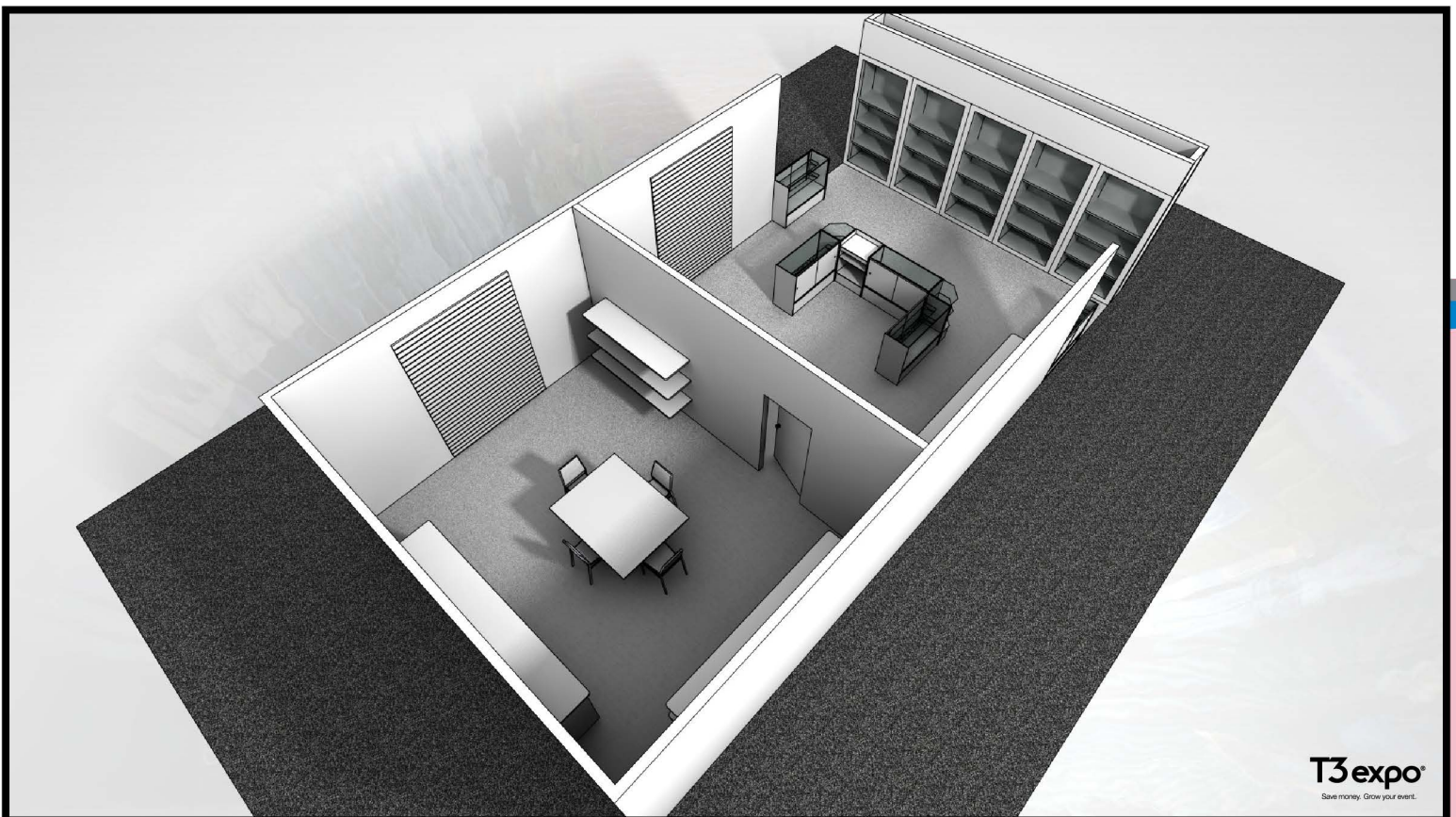
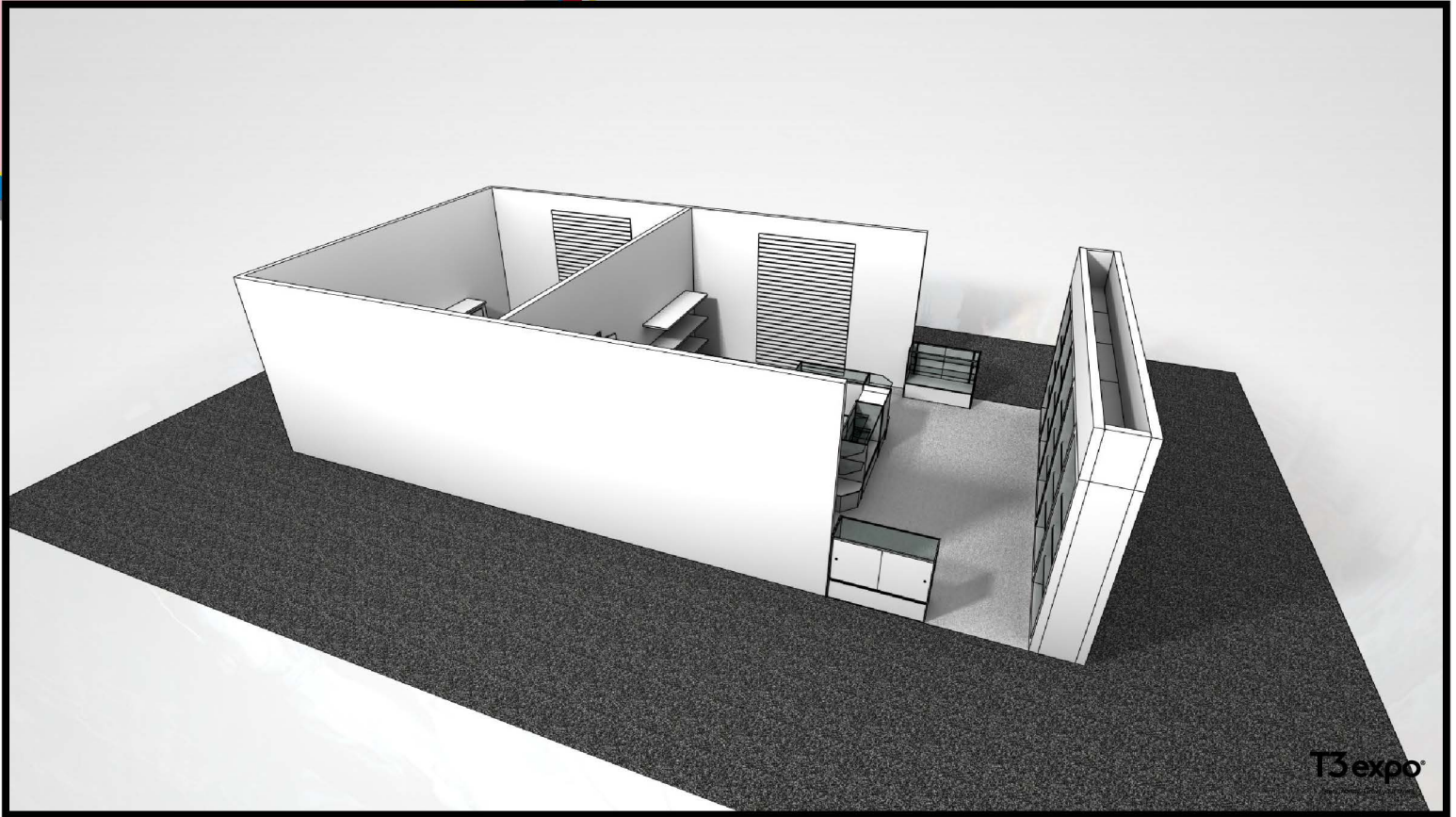

Walk-Thru Booths

Example D

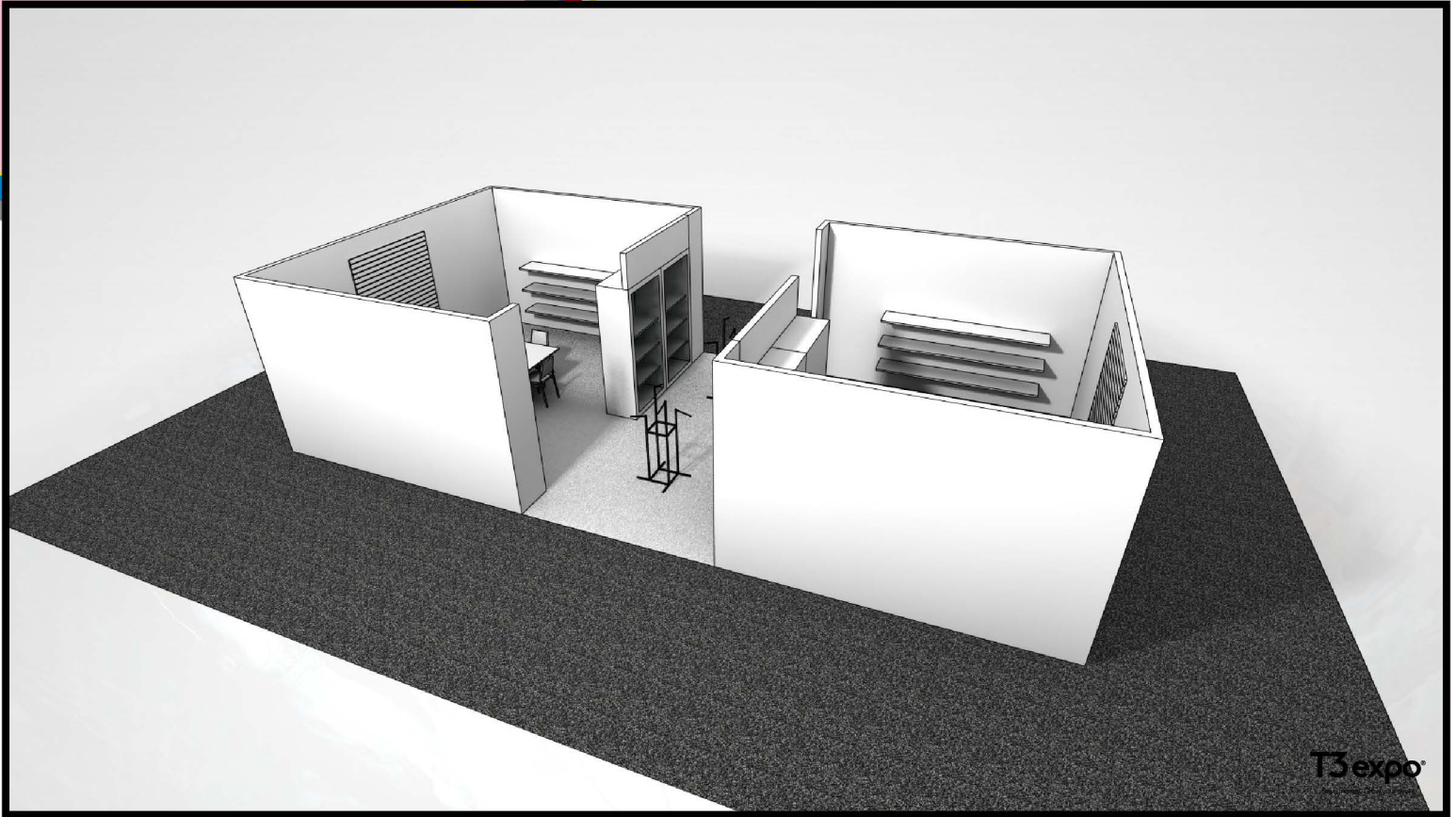
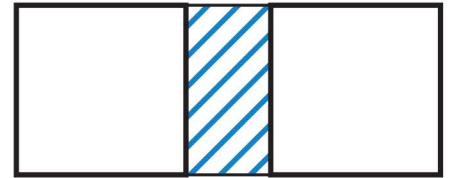

T3expo

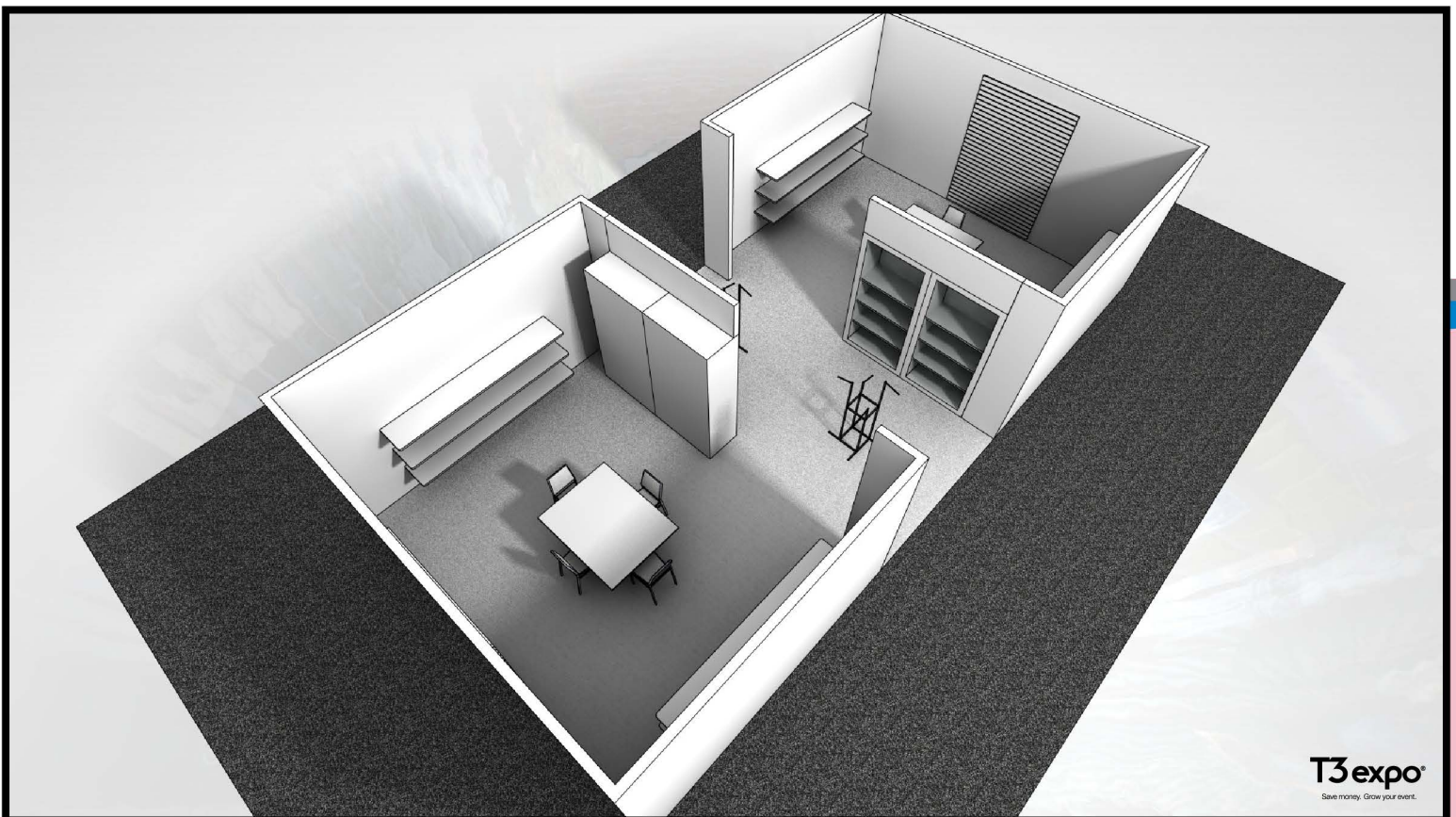

T3expo
Save money. Grow your event.

Booth Display Regulations

5. Peninsula Booths

Definition: An exhibit made up of four or more standard units back-to-back (i.e., 20'x20') with aisles on three sides and a backwall adjacent to neighboring exhibits.

All peninsula booth floor plan designs must be reviewed and approved by Show Management. Submissions must be received no later than Friday, November 1, 2024, [via this link](#).

If a display does not adhere to these regulations, exhibitors will be required to modify their exhibits on-site at their own expense.

Visual Merchandising Initiative: All peninsula booths must contain visual merchandising of product(s) or properties on at least 20% of the aisle-facing exhibit square footage.

This regulation provides the flexibility to include showcases, plexiglass, low walls, open space, etc. See the following pages for booth examples.

Purpose: Each exhibit space has specific business purposes. To provide engagement requested by the buying community and to leverage media attention, the minimum 20% visual merchandising allows exhibitors to present in-year product readily visible while also having the flexibility to host private meetings for preview activity.

Height Regulation for Level 3, Hall 3D (Aisles 900, 1000, 1100 & 1200): The maximum height for merchandise and display fixtures is 12ft. (3.66m). Any portion of the exhibit bordering another exhibitor's booth must have the back side of that portion finished and must not carry identification signs.

Height Regulation for all other areas on Level 3 (Halls 3, 3A, 3B & 3E): The maximum height for merchandise and display fixtures is 16ft. (4.88m). Any portion of the exhibit bordering another exhibitor's booth must have the back side of that portion finished and must not carry identification signs.

Height Regulation for Level 1: The maximum height for merchandise and display fixtures is 12ft. (3.66m). Any portion of the exhibit bordering another exhibitor's booth must have the back side of that portion finished and must not carry identification signs.

Notes: Back drape is 8' high.

Any unfinished sides of displays must be covered or draped at the exhibitor's expense.

No product may be hung on the exterior side of display.

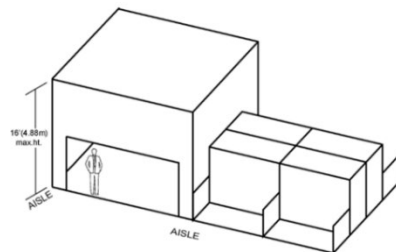

Level 3, Hall 3D - 12ft. (3.66m) max.
Level 3, Halls 3/3A/3B/3E - 16ft. (4.88m) max.
Level 1, Halls 1A/1B/1C - 12ft. (3.66m) max.

IMPORTANT:

Peninsula booths are normally faced towards the cross aisle. Any portion of the exhibitor's booth adjacent to another booth must have the back side of that portion finished and must not carry identification or other copy that would detract from the adjoining exhibit.

Structural Integrity

All multi-story exhibits, regardless of whether people will occupy the upper area or not, and all exhibit fixtures and components exceeding 12ft.(3.66m) in height must have drawings available for inspection by Show Management, the installation and dismantling contractor, the exhibitor and governmental authority. These must be available during the time the exhibit is being erected, exhibited and dismantled at the show site and must include a signature or stamp of a reviewing structural engineer indicating that the structure design is properly engineered for its proposed use, and a signature of an authorized official of the exhibit building company indicating that the structure is built in compliance with the details and specifications set forth on the drawings. Signs must also be posted indicating the maximum number of people the structure will accommodate.

*Nothing may be taped, tacked, nailed, or screwed or affixed in any way to columns, walls, floors, or other Javits Center surfaces. Any damage caused by infraction of this rule will be repaired at the exhibitor's expense.

Peninsula Booths

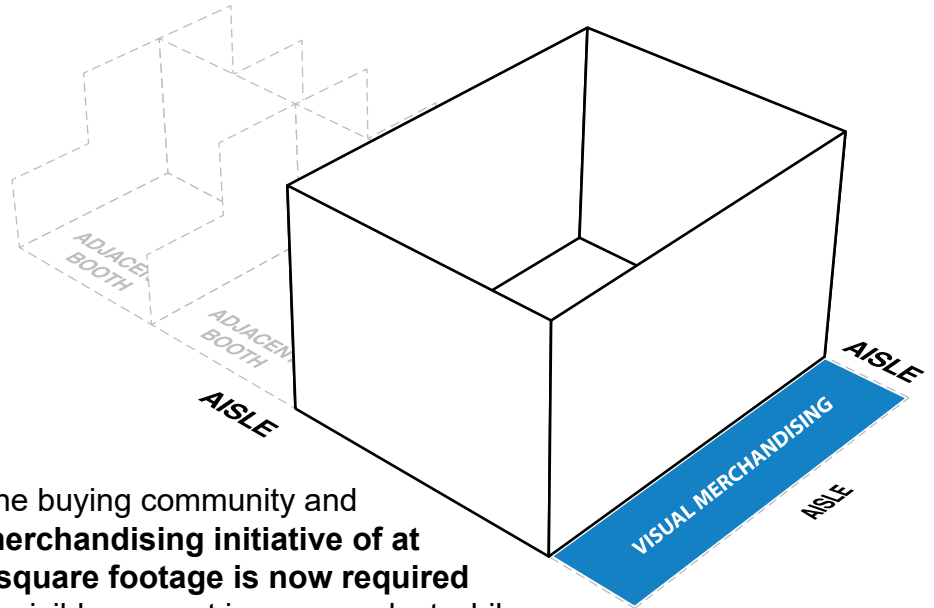

To provide engagement requested by the buying community and to leverage media attention, **a visual merchandising initiative of at least 20% of the aisle-facing exhibit square footage is now required for all exhibitors.** This will allow you to visibly present in-year product while also having the flexibility to host private meetings for preview activity.

To calculate the required visual merchandising space, (Length x Width) x 20%.

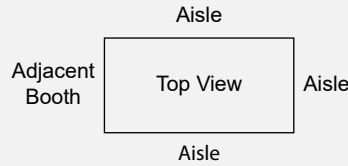

“Visual merchandising provides the flexibility to include window displays, windows, display cases, kneewalls, open space, etc.

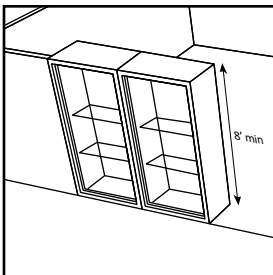

window display

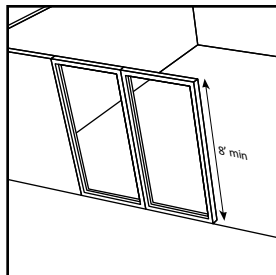

window

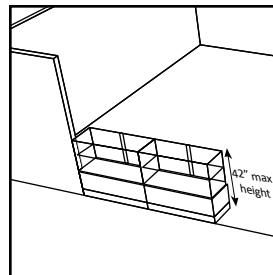

counter height display case

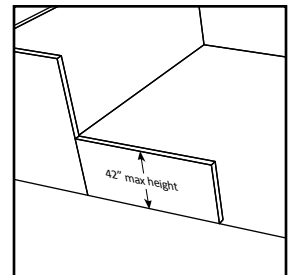

kneewall

Booth Layout Examples Top View

Key

- Booth Wall
- Visual Merchandising Space



Example A



Example B



Example C



Example D

Peninsula Booths

Example A

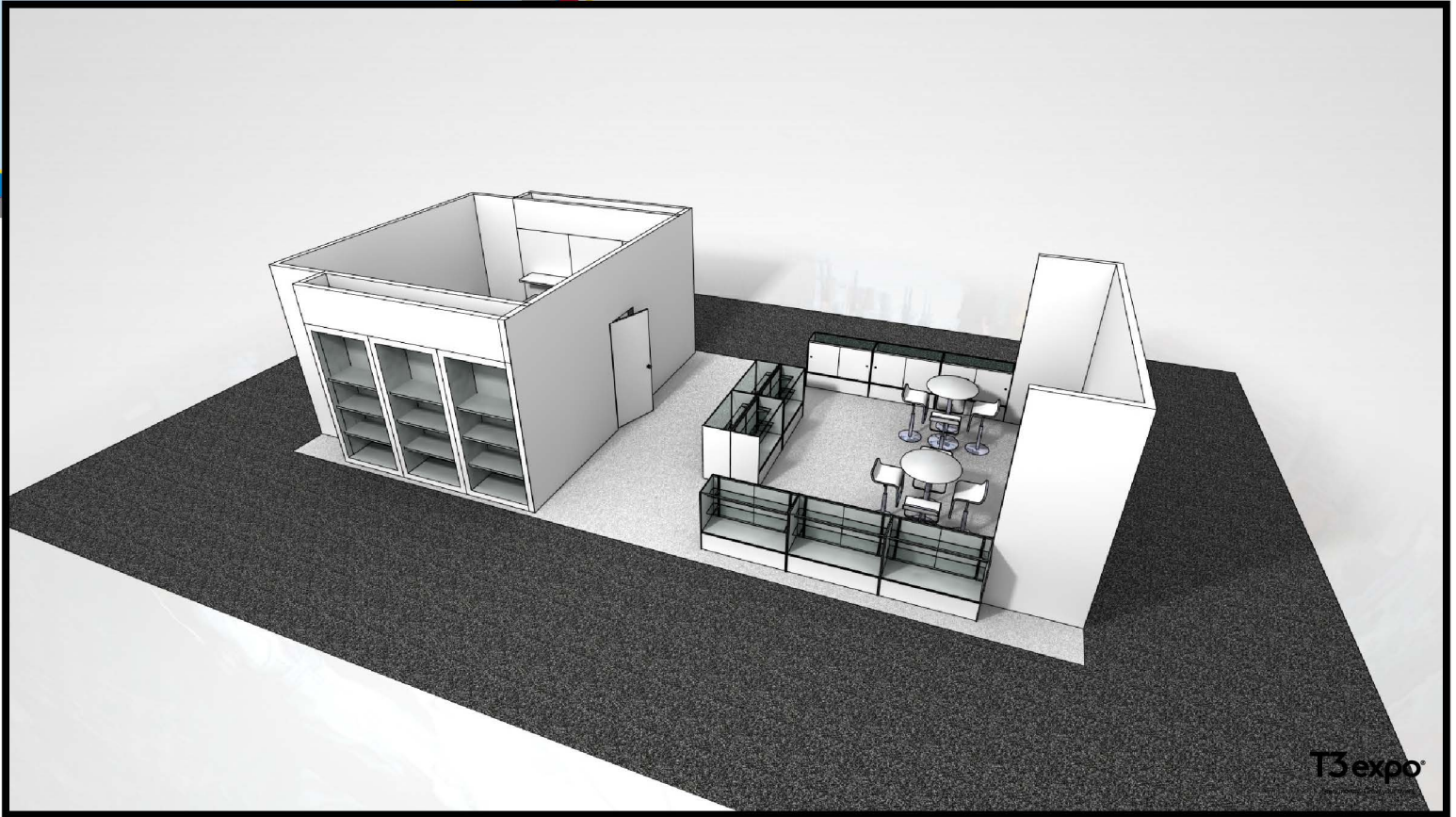
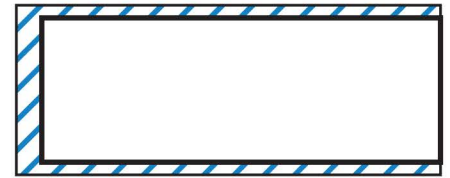

T3expo



T3expo
Save money. Grow your event.

Peninsula Booths

Example B

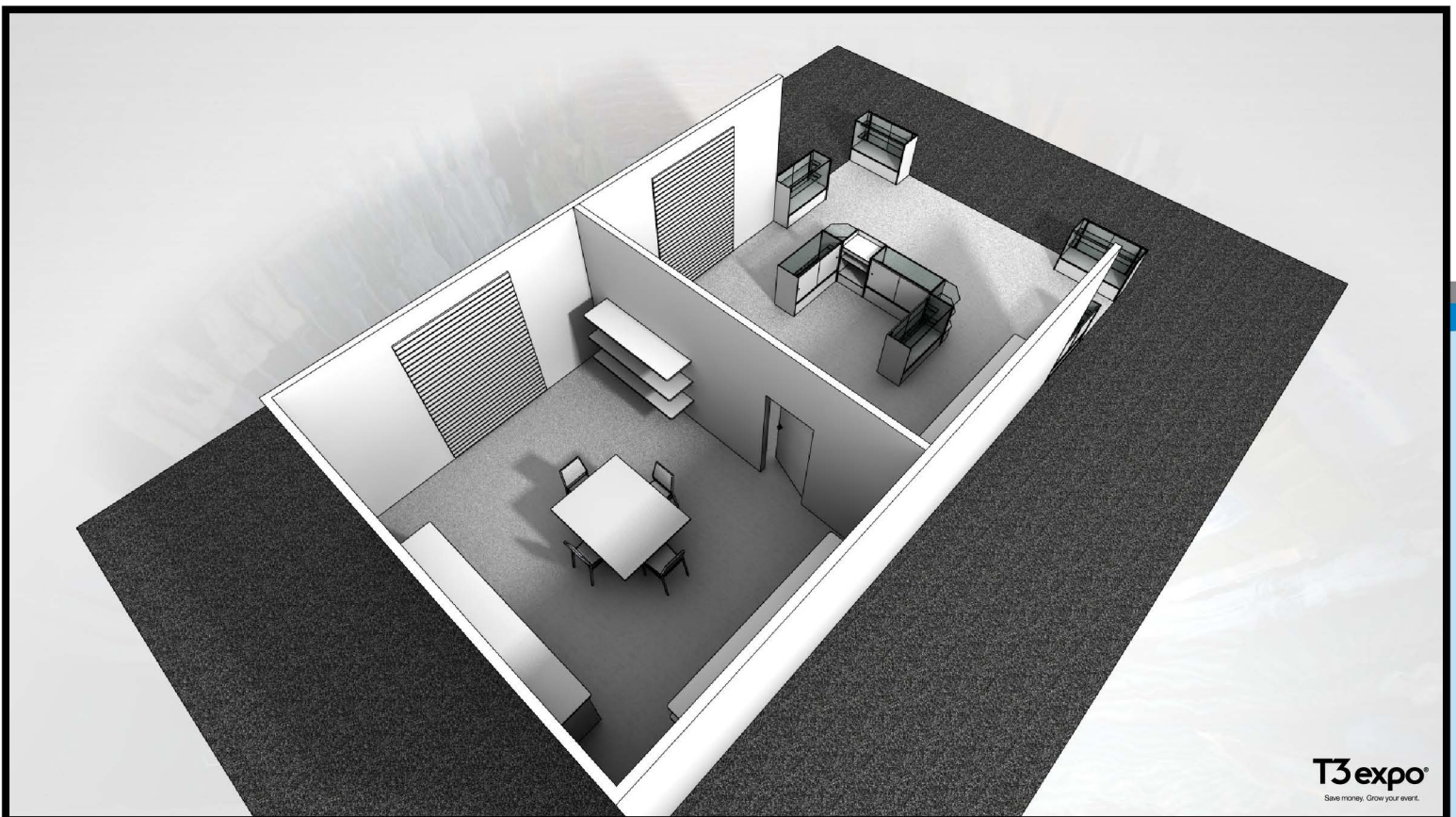
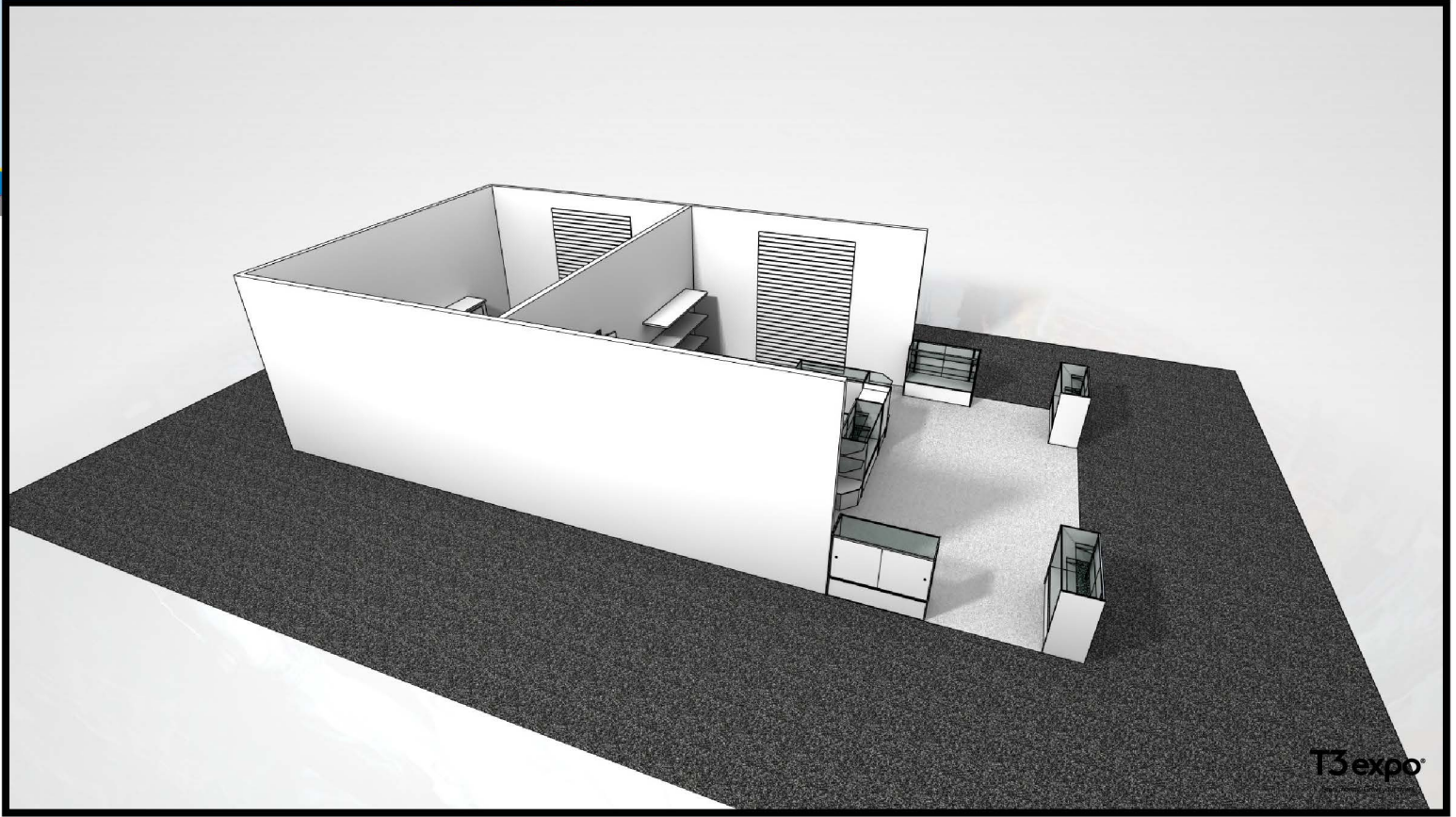

Peninsula Booths

Example C

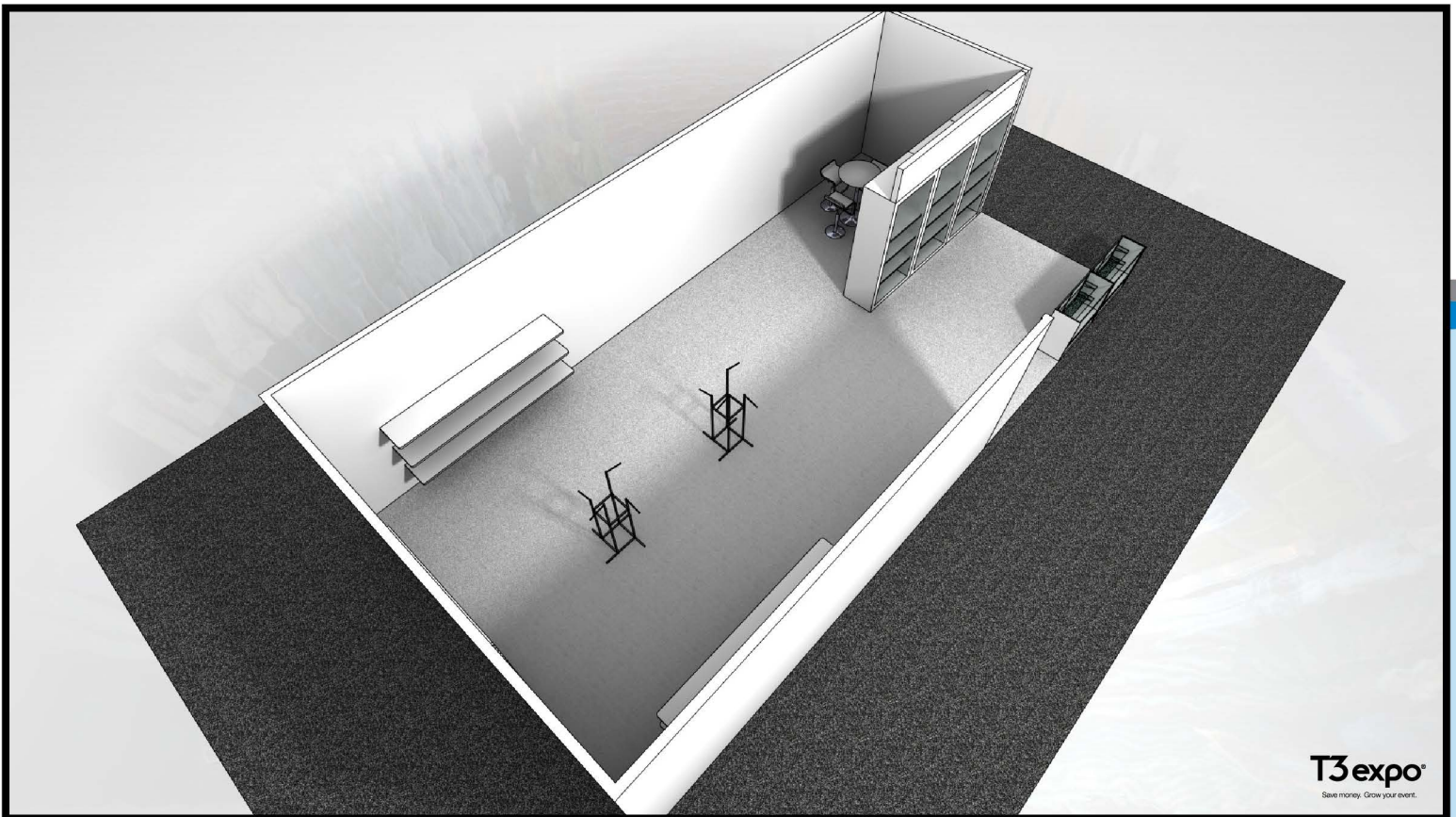
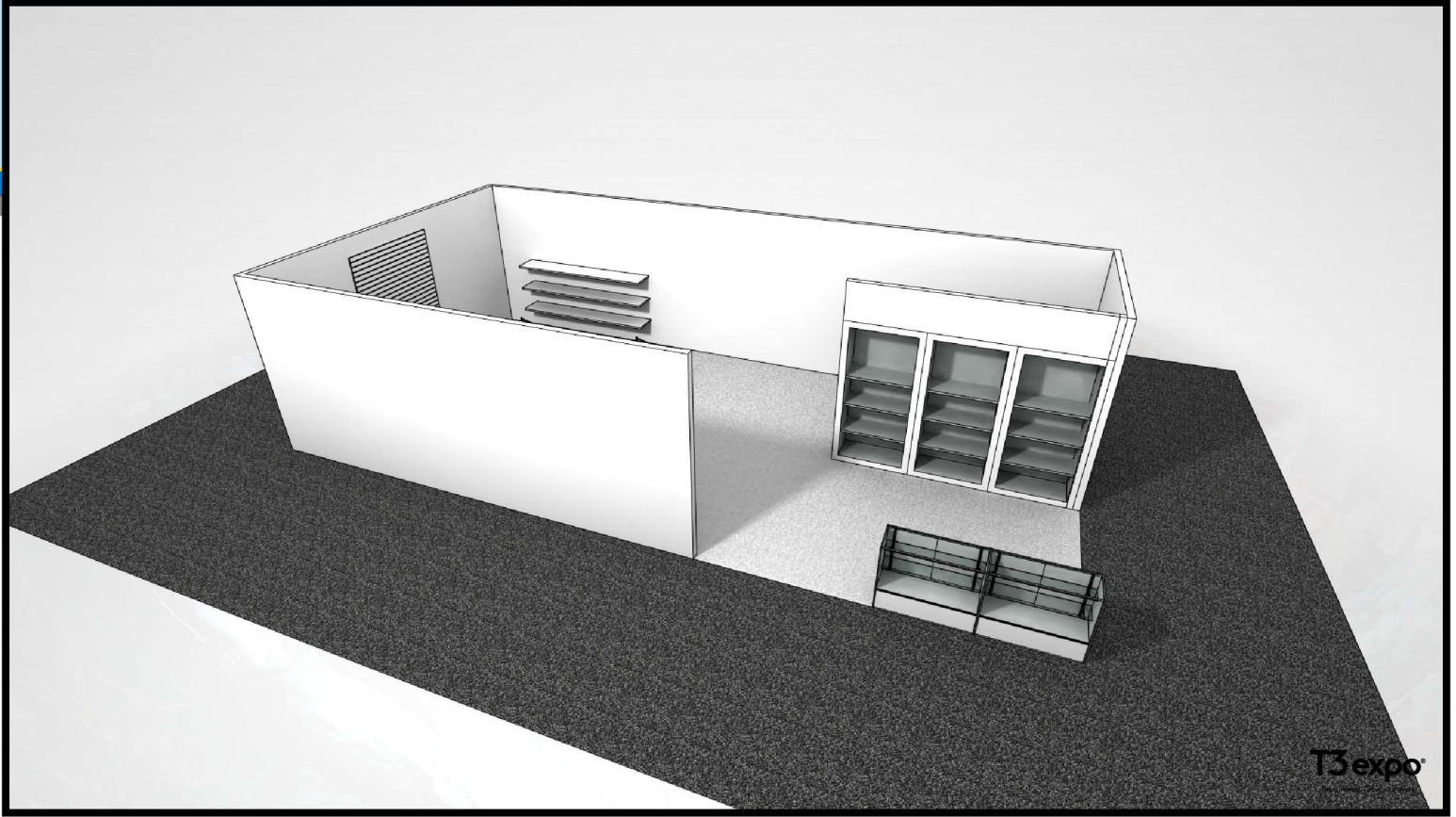
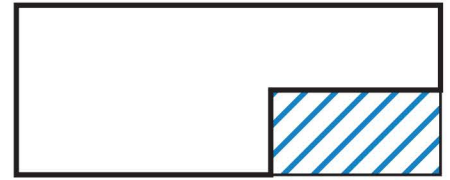

Peninsula Booths

Example D

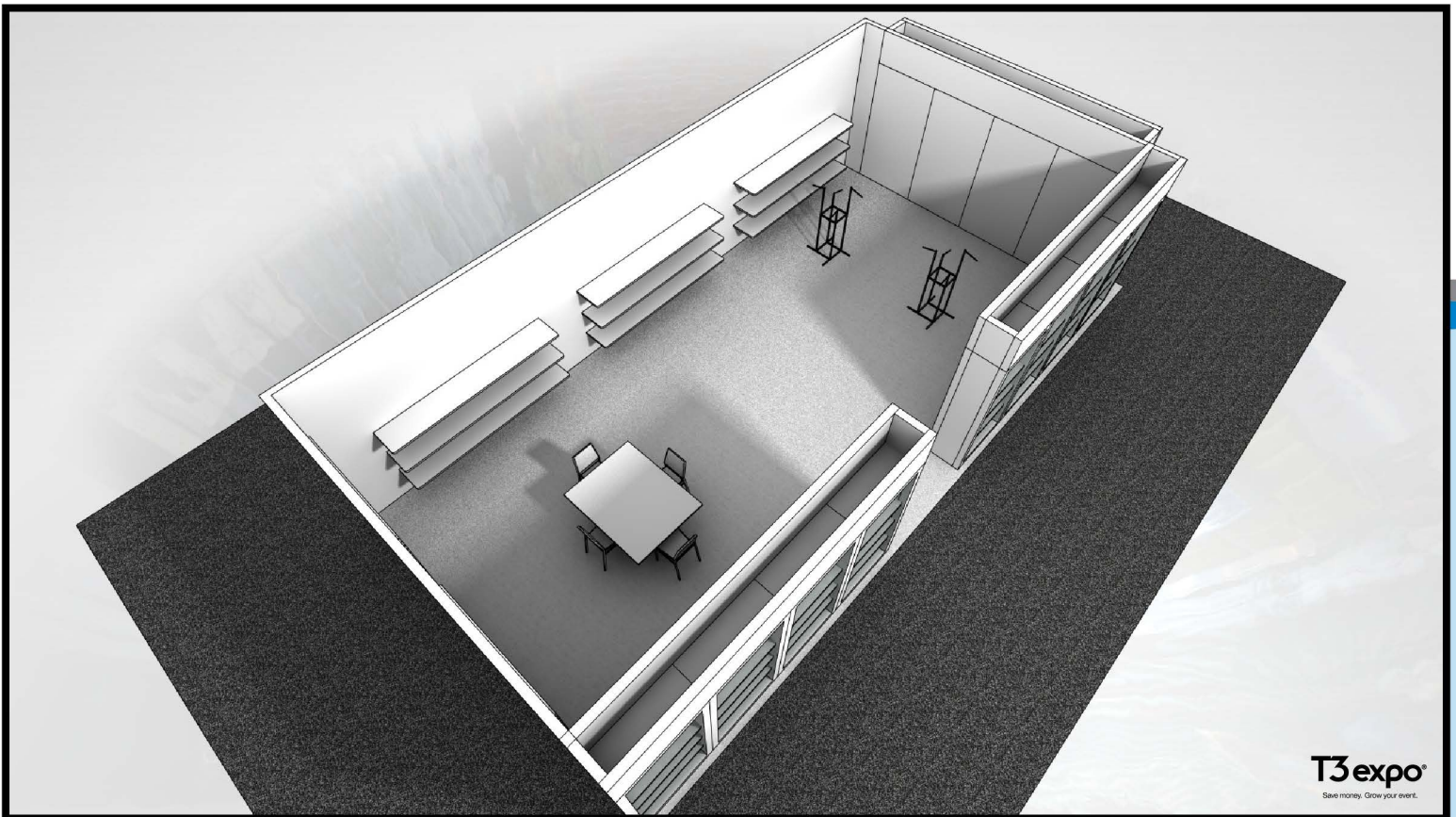
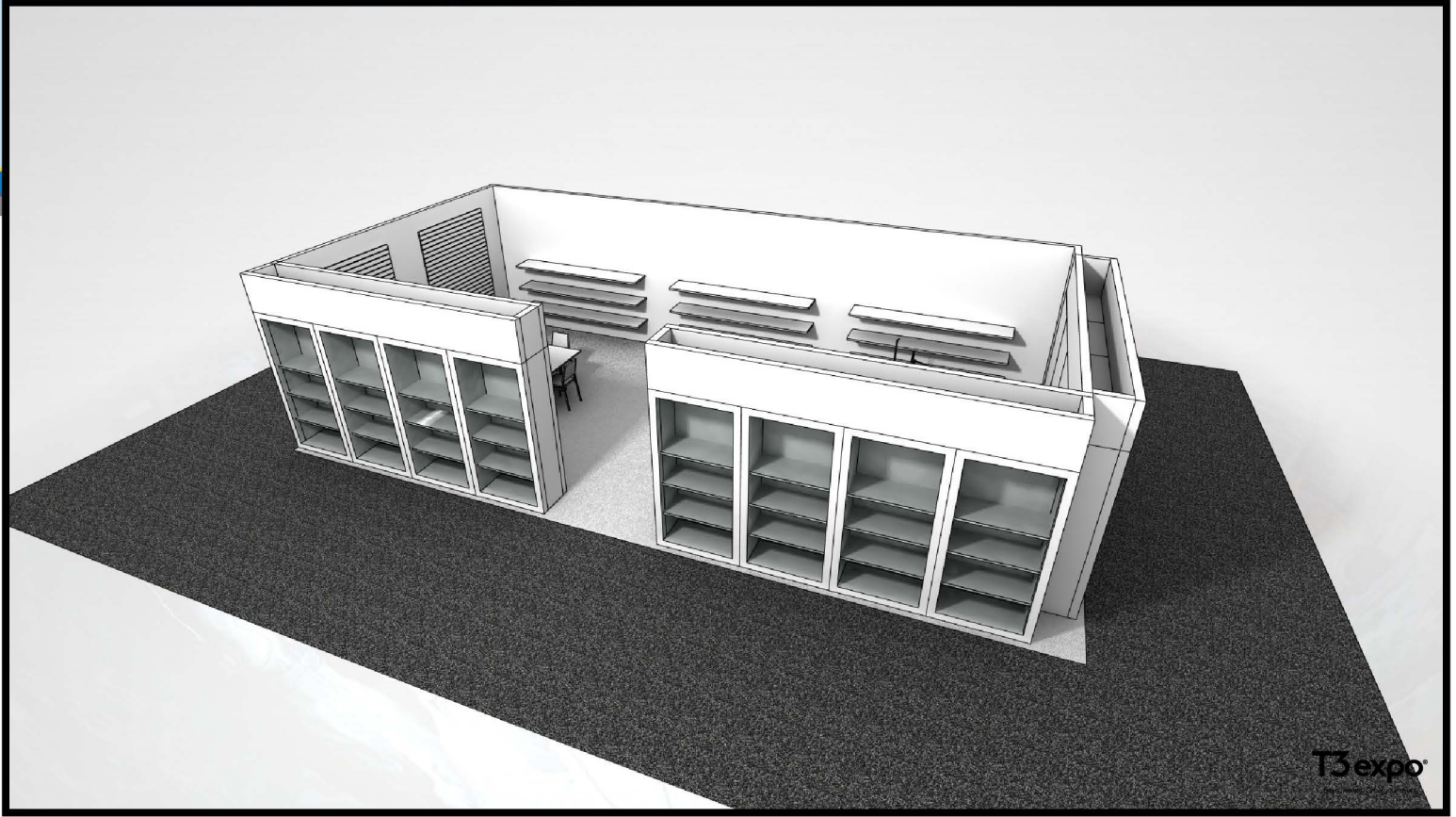

Booth Display Regulations

6. Island Booths

Definition: An exhibit with at least four or more standard units back-to-back (i.e., 20'x20') with aisles on all four sides.

All island booth floor plan designs must be reviewed and approved by Show Management. Submissions must be received no later than Friday, November 1, 2024, [via this link](#).

If a display does not adhere to these regulations, exhibitors will be required to modify their exhibits on-site at their own expense.

Visual Merchandising Initiative: All island booths must contain visual merchandising of product(s) or properties on at least 20% of the aisle-facing exhibit square footage.

This regulation provides the flexibility to include showcases, plexiglass, low walls, open space, etc. See the following pages for booth examples.

Purpose: Each exhibit space has specific business purposes. To provide engagement requested by the buying community and to leverage media attention, the minimum 20% visual merchandising allows exhibitors to present in-year product readily visible while also having the flexibility to host private meetings for preview activity.

Height Regulation for Level 3, Hall 3D (Aisles 900, 1000, 1100 & 1200): The maximum height for merchandise and display fixtures is 12ft. (3.66m).

Height Regulation for all other areas on Level 3 (Halls 3, 3A, 3B & 3E): The maximum height for merchandise and display fixtures is 16ft. (4.88m).

Height Regulation for Level 1: The maximum height for merchandise and display fixtures is 12ft. (3.66m).

Notes: Any unfinished sides of displays must be covered or draped at the exhibitor's expense.
No product may be hung on the exterior side of display.

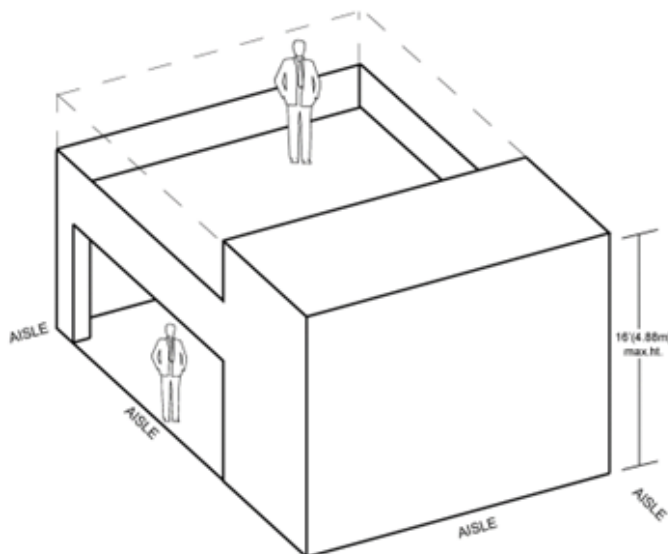

Structural Integrity

All multi-story exhibits, regardless of whether people will occupy the upper area or not, and all exhibit fixtures and components exceeding 12ft.(3.66m) in height must have drawings available for inspection by Show Management, the installation and dismantling contractor, the exhibitor and governmental authority. These must be available during the time the exhibit is being erected, exhibited and dismantled at the show site and must include a signature or stamp of a reviewing structural engineer indicating that the structure design is properly engineered for its proposed use, and a signature of an authorized official of the exhibit building company indicating that the structure is built in compliance with the details and specifications set forth on the drawings. Signs must also be posted indicating the maximum number of people the structure will accommodate.

Level 3, Hall 3D - 12ft. (3.66m) max.

Level 3, Halls 3/3A/3B/3E - 16ft. (4.88m) max.

Level 1, Halls 1A/1B/1C - 12ft. (3.66m) max.

*Nothing may be taped, tacked, nailed, or screwed or affixed in any way to columns, walls, floors, or other Javits Center surfaces. Any damage caused by infraction of this rule will be repaired at the exhibitor's expense.

Island Booths

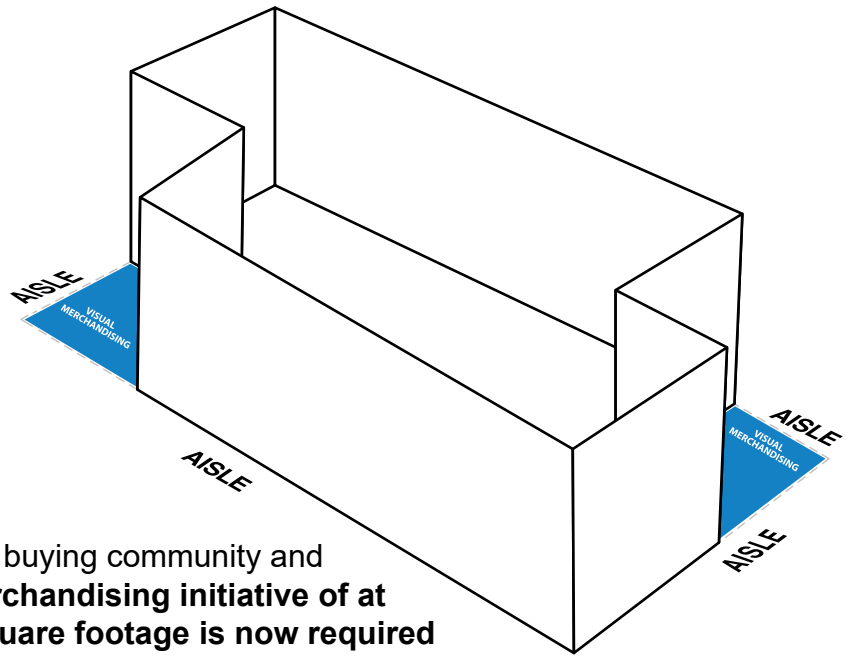

To provide engagement requested by the buying community and to leverage media attention, **a visual merchandising initiative of at least 20% of the aisle-facing exhibit square footage is now required for all exhibitors.** This will allow you to visibly present in-year product while also having the flexibility to host private meetings for preview activity.

To calculate the required visual merchandising space, (Length x Width) x 20%.

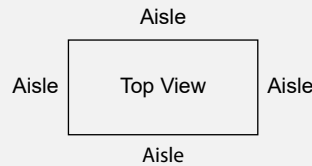

“Visual merchandising provides the flexibility to include window displays, windows, display cases, kneewalls, open space, etc.

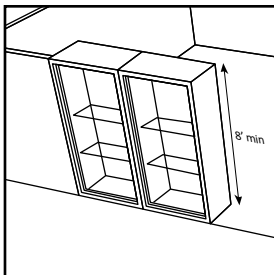

window display

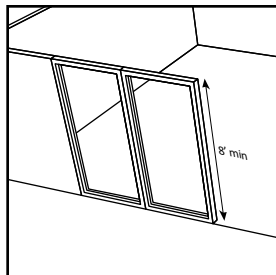

window

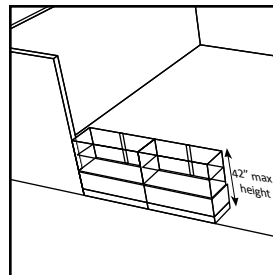

counter height display case

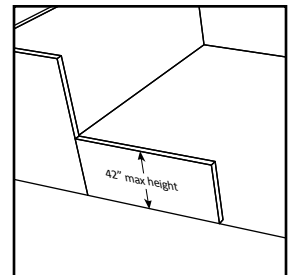

kneewall

Booth Layout Examples Top View

Key

- Booth Wall
- Visual Merchandising Space



Example A



Example B



Example C

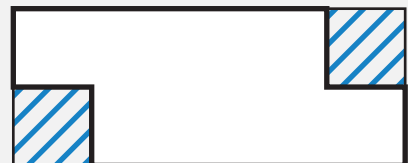

Example D

Island Booths

Example A

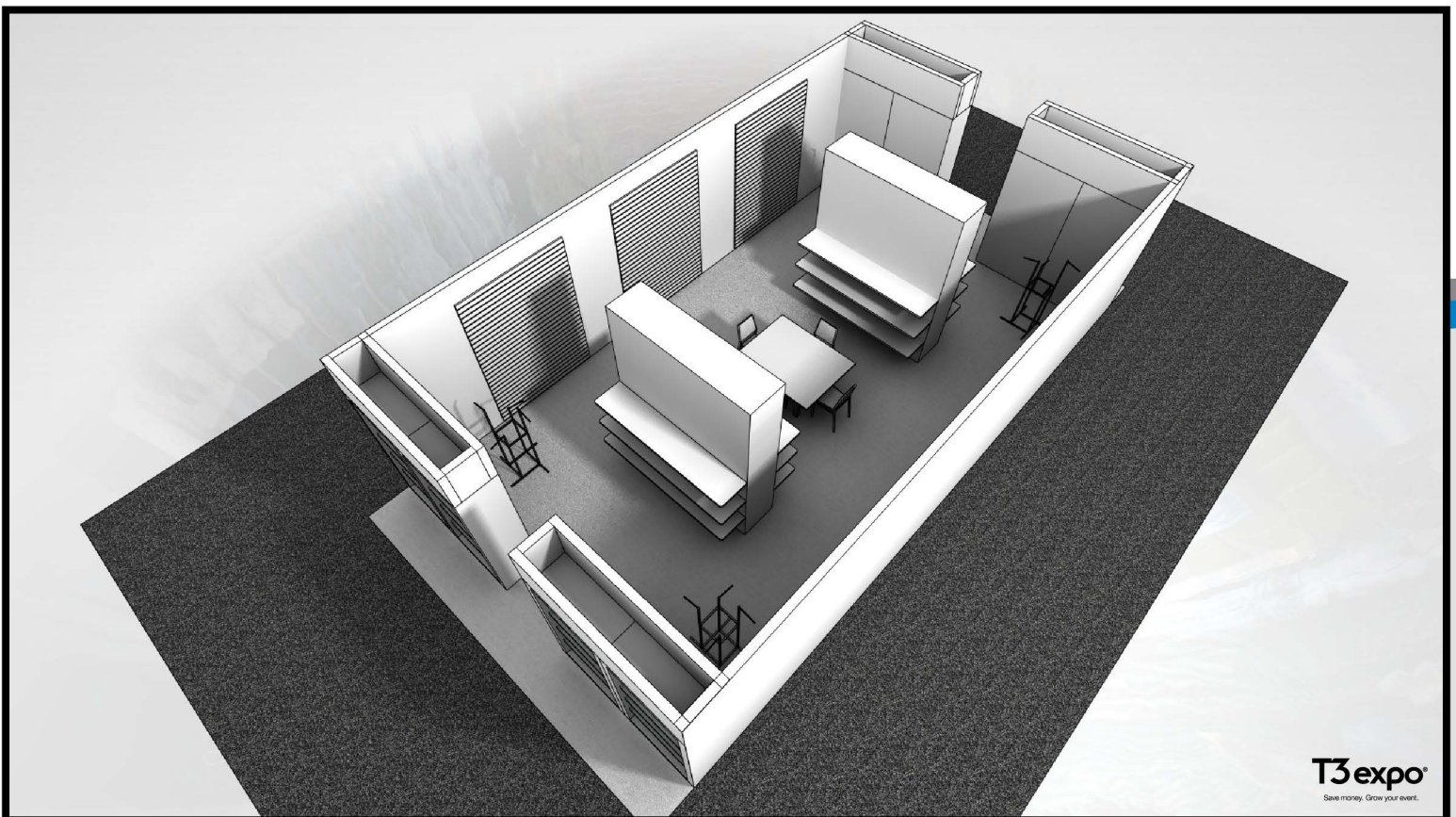
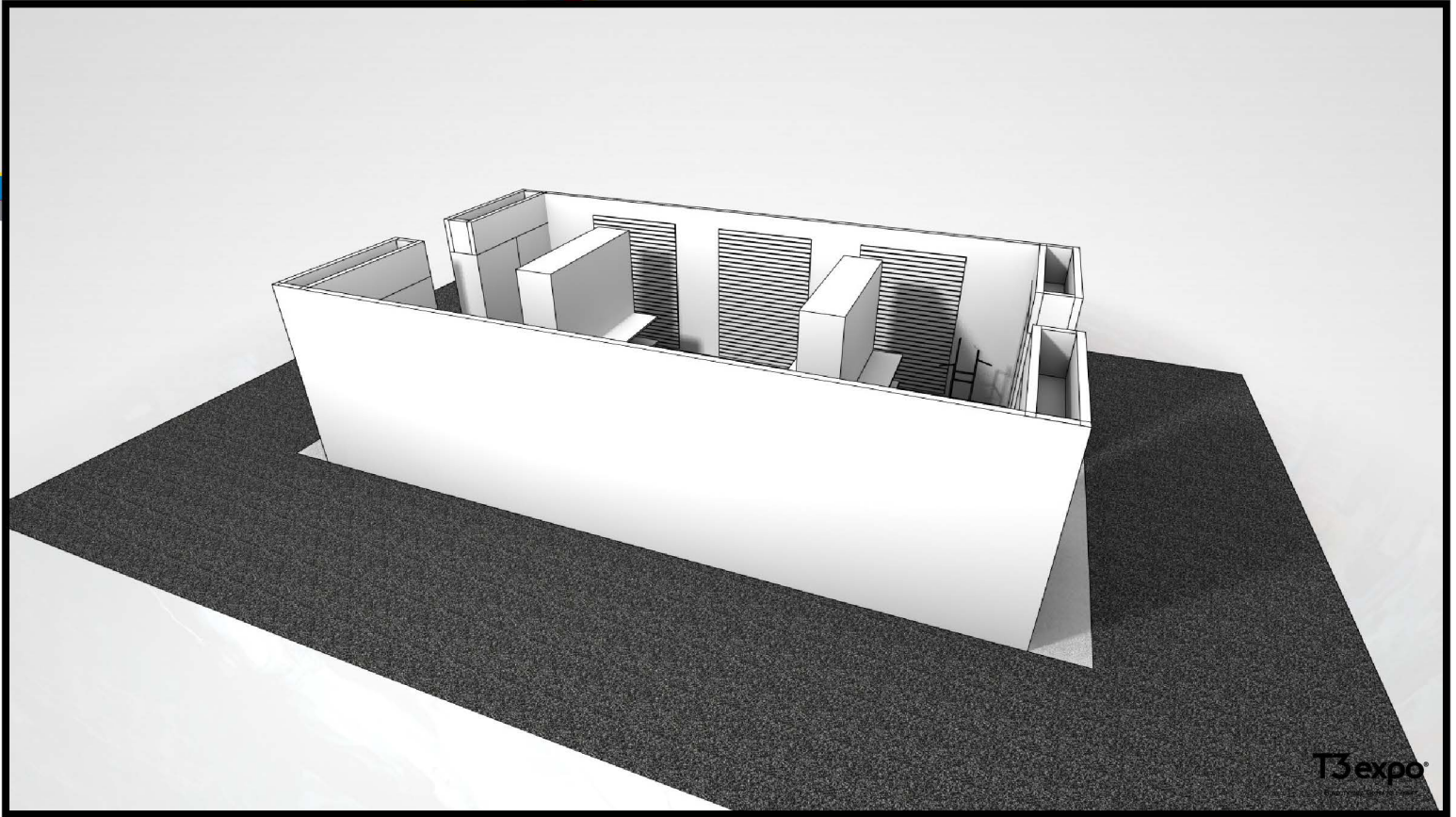

Island Booths

Example B

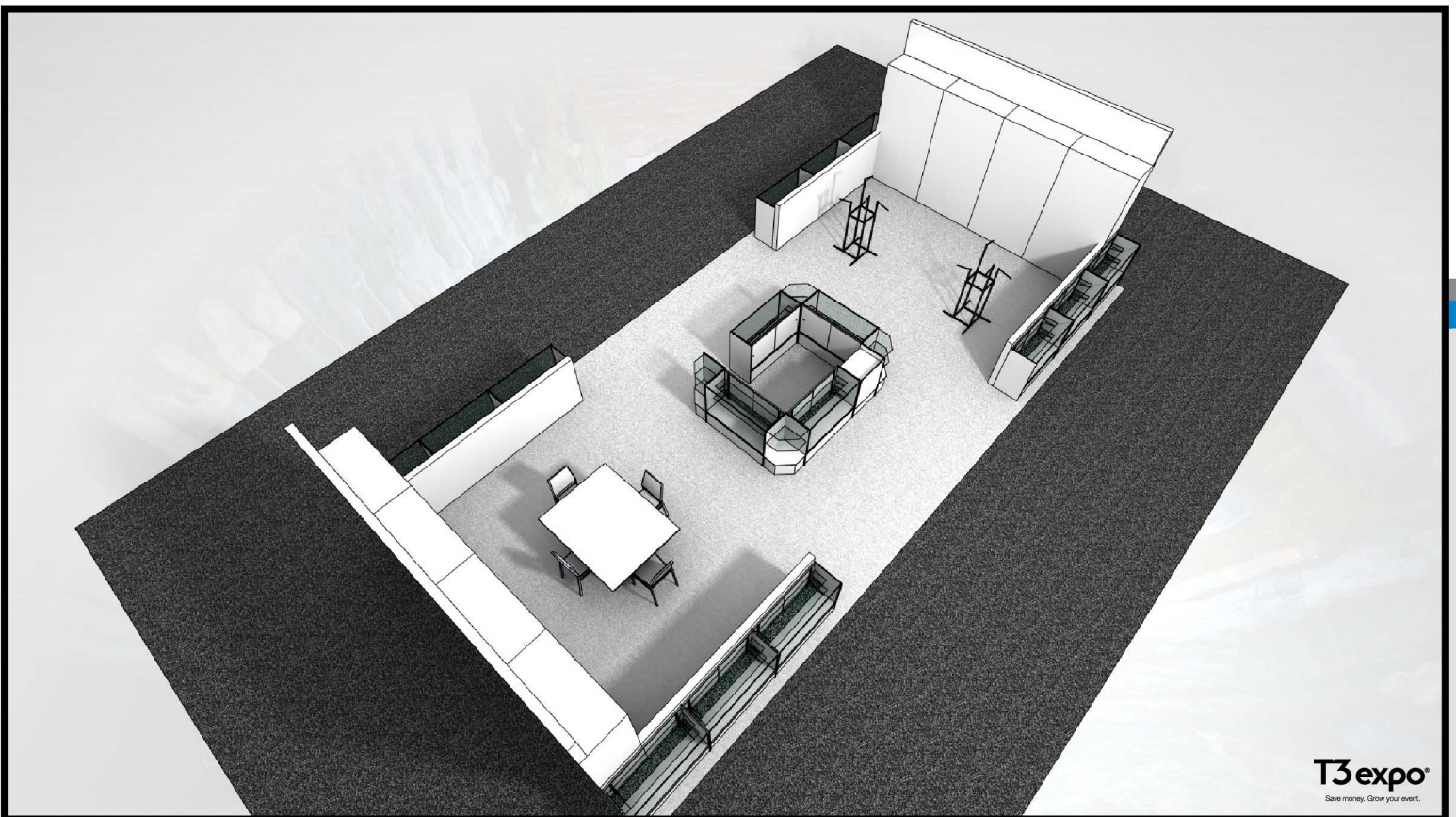
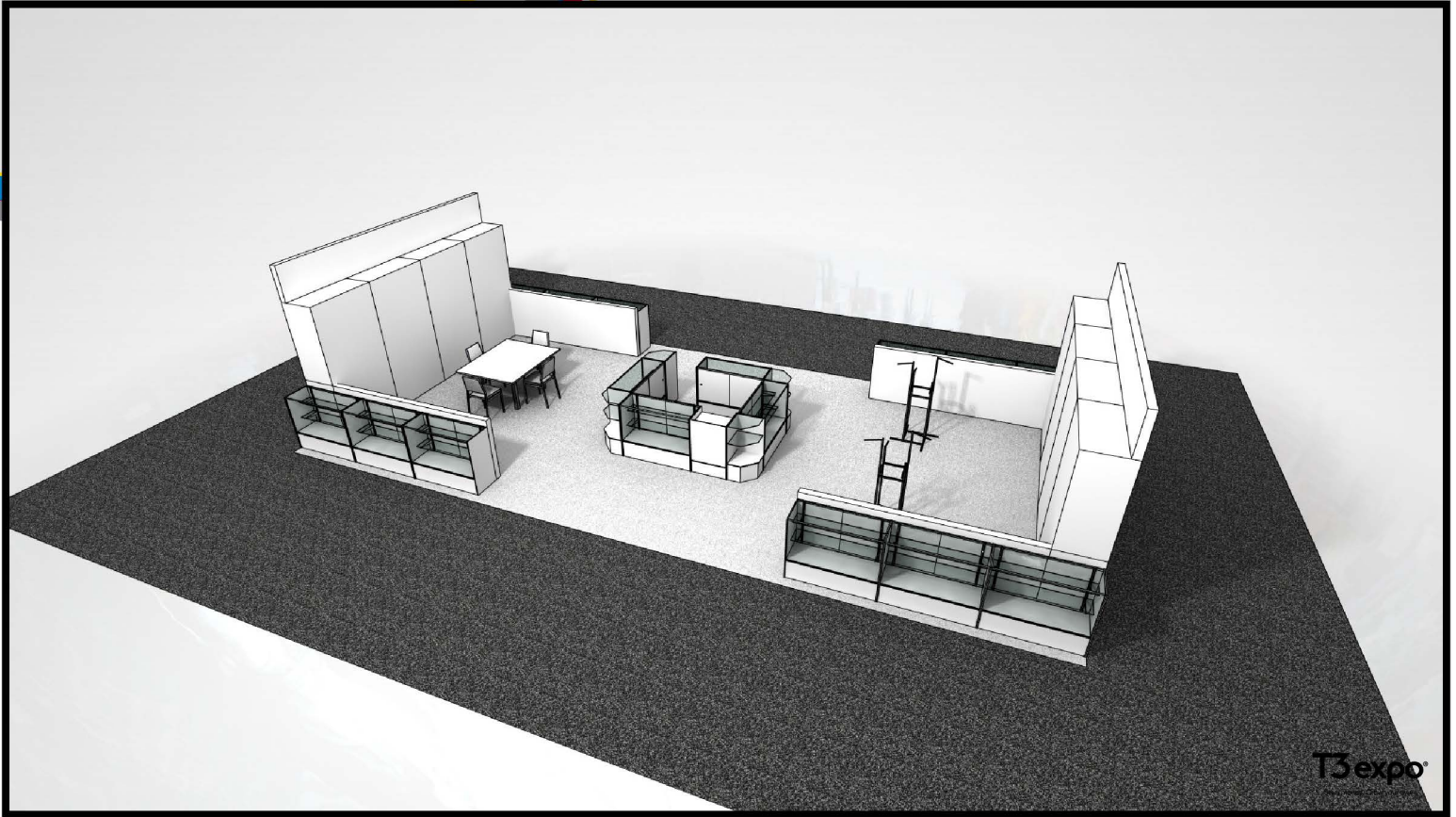

Island Booths

Example C

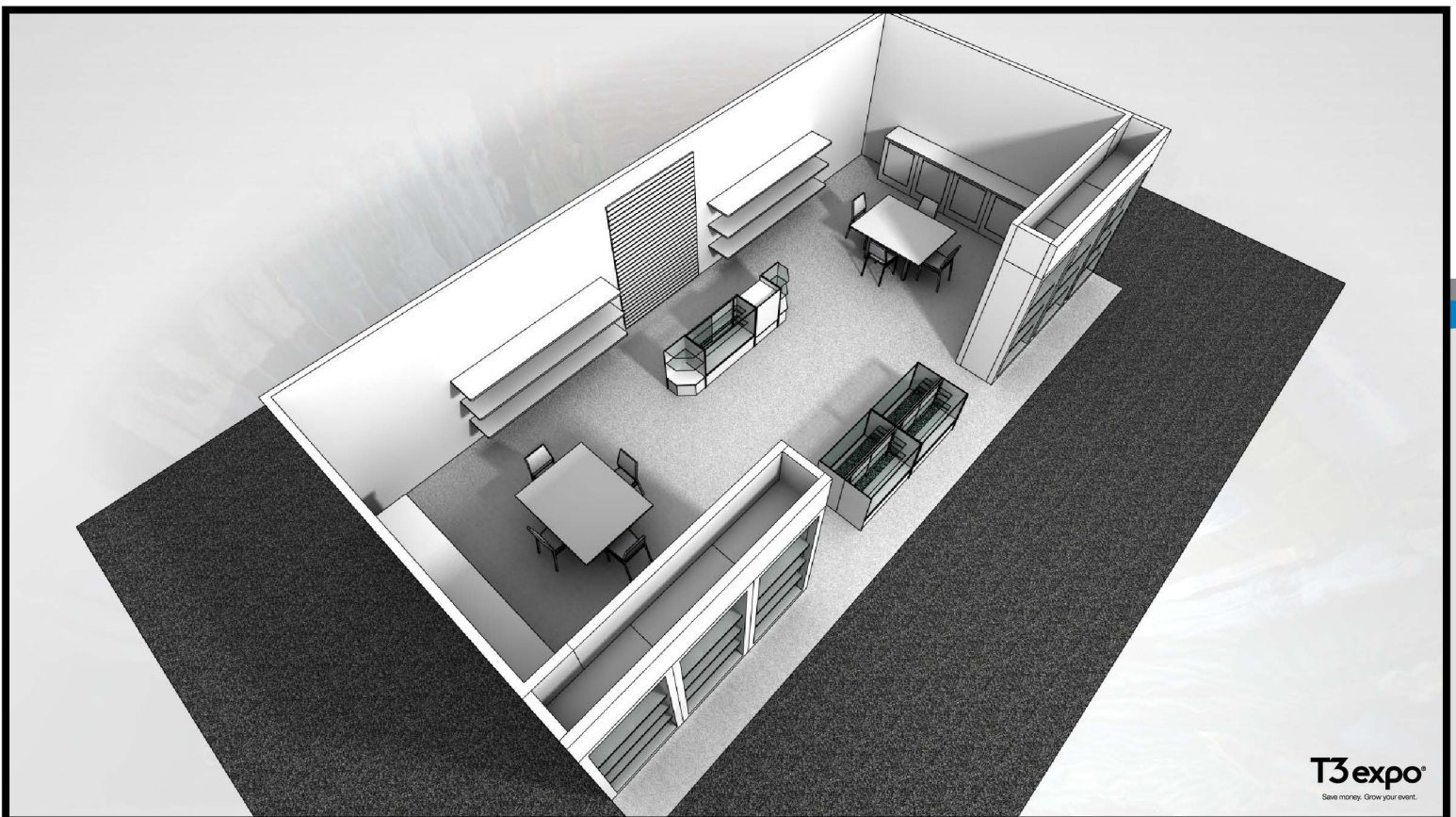
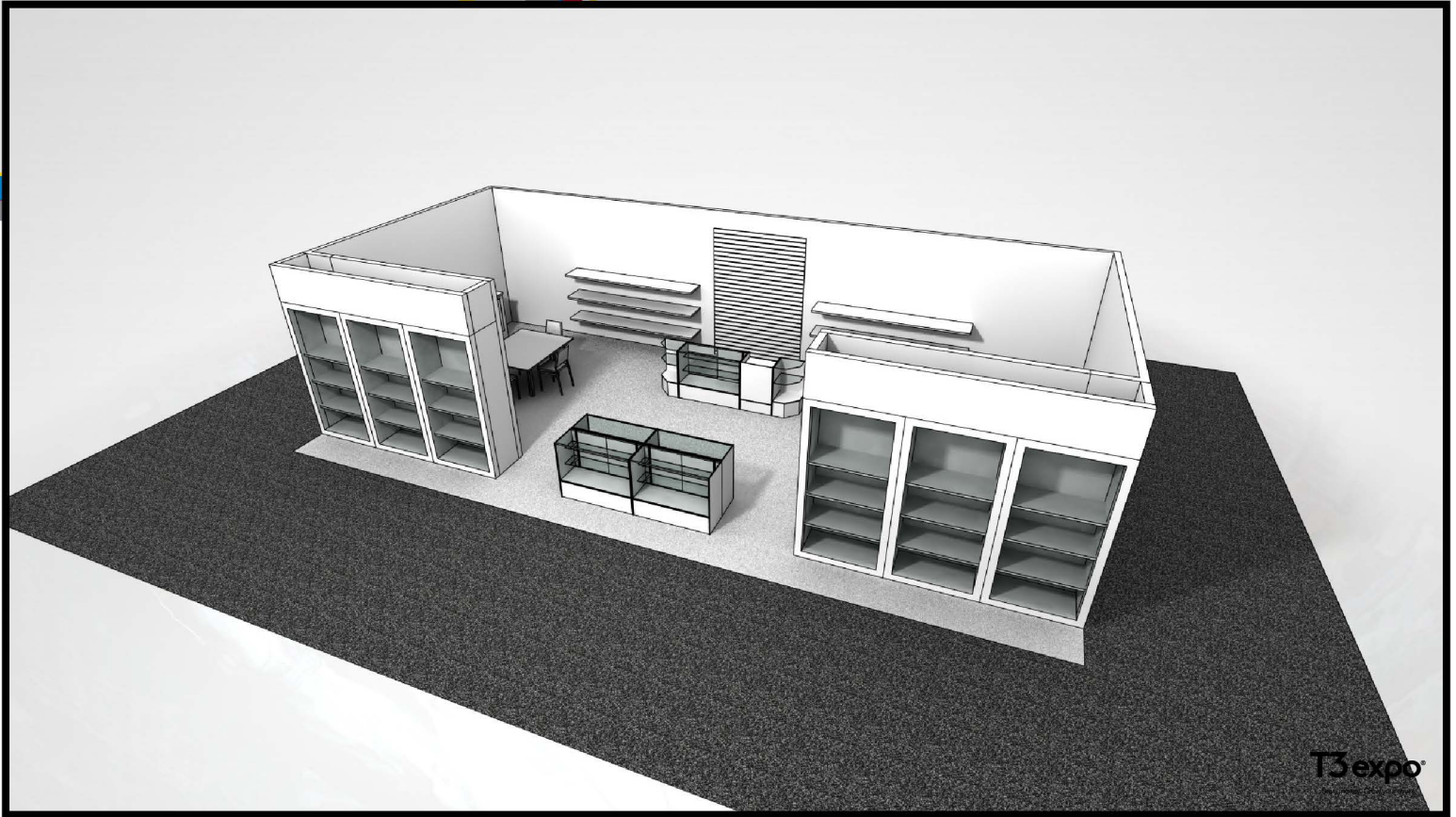

Island Booths

Example D

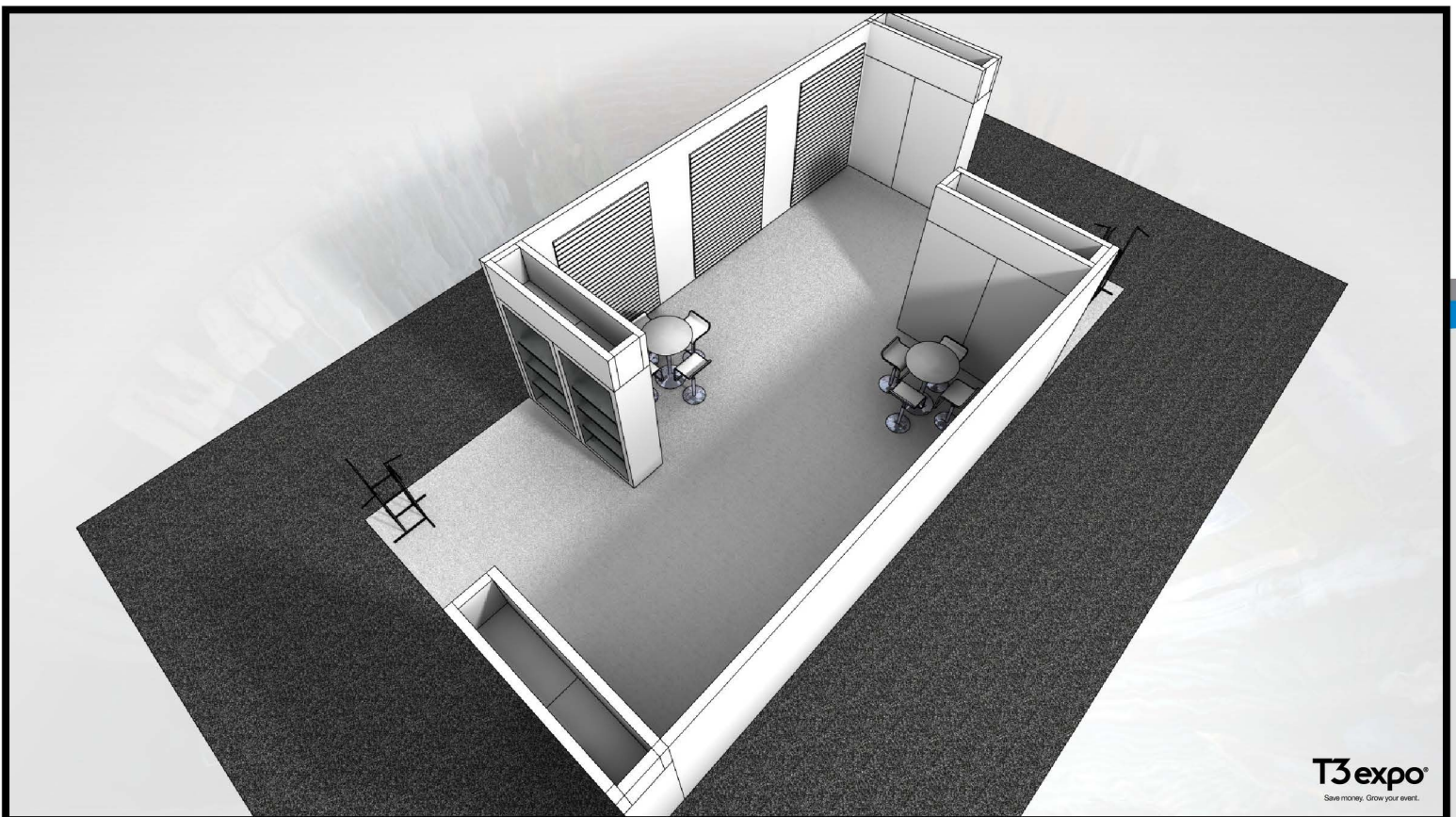
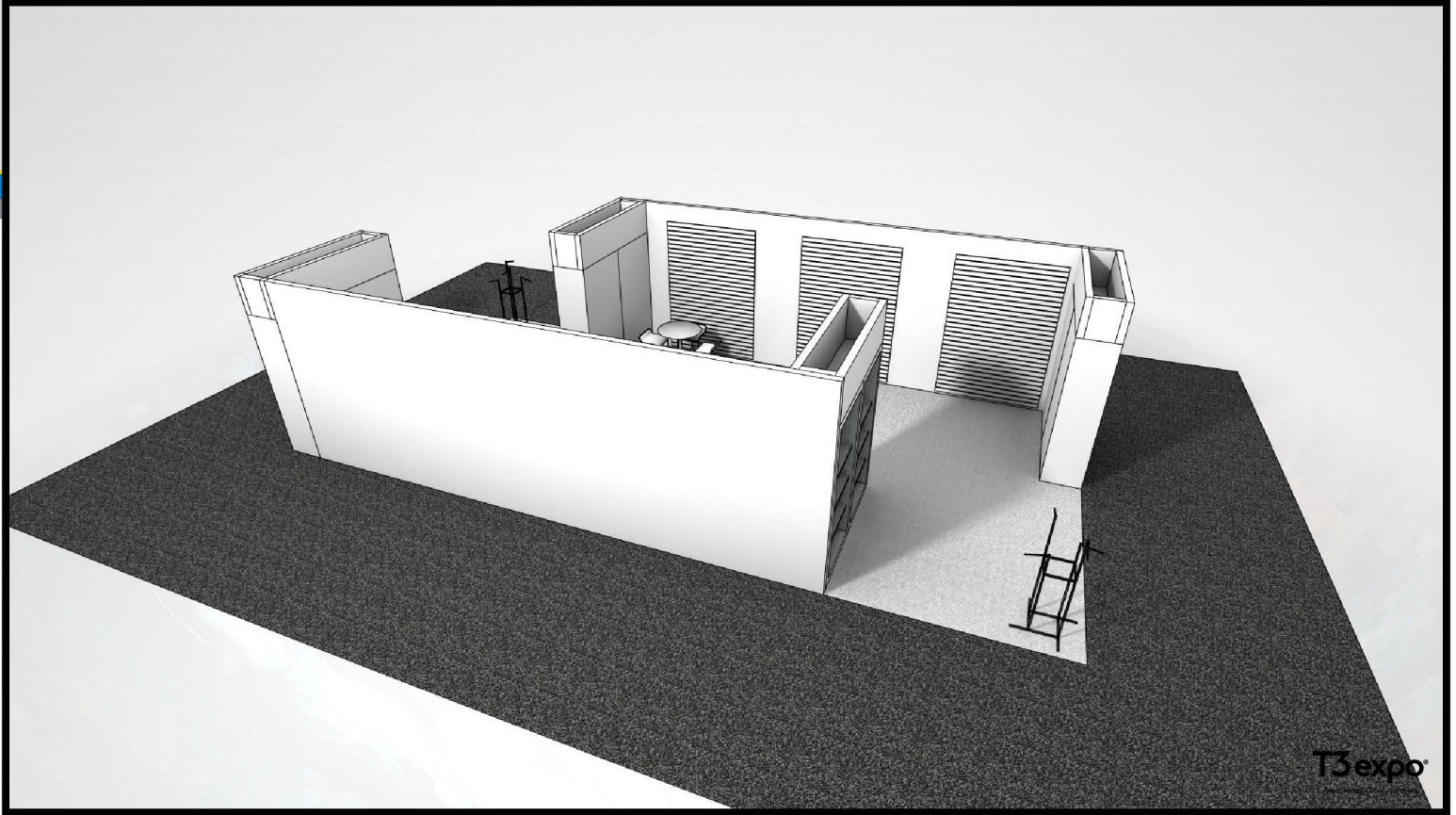

7. Launch Pad Tabletops

Definition: A tabletop unit located in Launch Pad on Level 1.

Each unit is equipped with:

- (1) – 6' table (6'W x 2'D x 2.5'H)
- (2) – chairs
- (1) – wastebasket
- (1) – ID sign
- carpet

Height Regulation: The maximum height for merchandise and/or display fixtures placed in the tabletop area is 6ft. (1.83m) off the ground, with the exception of a background sign/banner (see notes below).

Notes: All product must be displayed and restricted to the surface area of the table provided.

Floor standing signs are not permitted.

A sign/banner may be hung on the pipe & drape behind the table using S-hooks and grommets. The sign/banner must be no wider than 4ft. and no higher than 8ft. The sign/banner (maximum dimensions of 4'W x 8'H) should line up with the table.

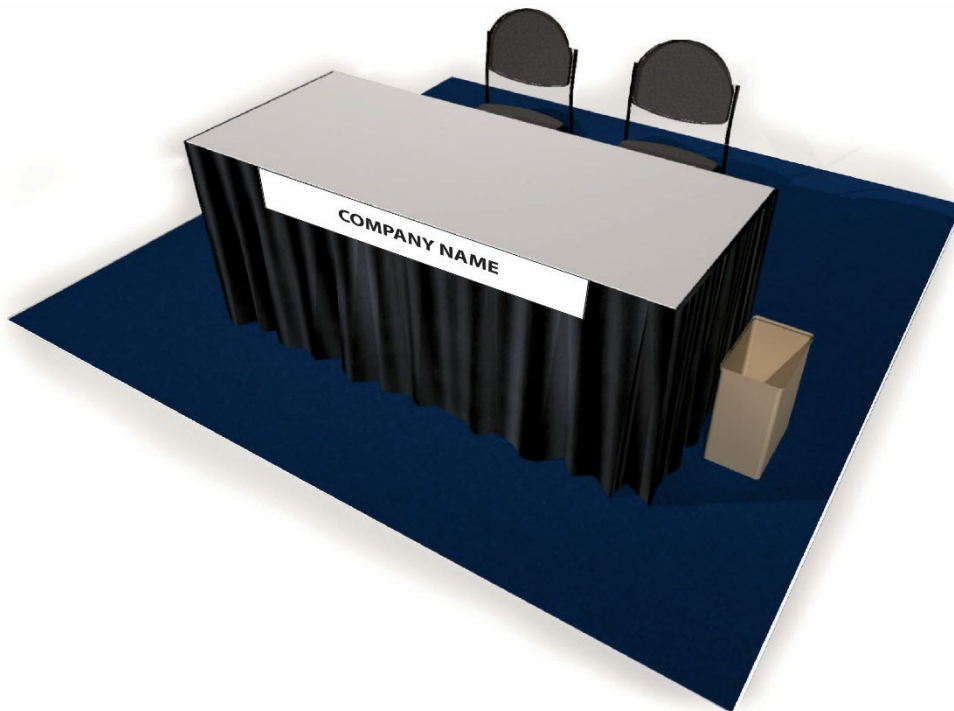

*Nothing may be taped, tacked, nailed, or screwed or affixed in any way to columns, walls, floors, or other Javits Center surfaces. Any damage caused by infraction of this rule will be repaired at the exhibitor's expense.